

Manufacturer: **Hatteland Technology AS**
 Product: **8.0 inch Maritime Multi Computer (MMC)**
 Type: **HD 08T30 MMC-2xx-xxxEAx**
 Description: RetroFit HD 08T21

Last Revised: **30 Nov 2022**
 Revision#: **35**

8.0 inch Maritime Multi Computer - Series X

Features:

Series X Small Panel Computers offer the ultimate in performance, convenience, state of the art design and enduring quality for system integrators and boat builders. The products offer a range of feature sets optimized for varying requirements and applications. Suitable for applications such as engine control systems, automation systems and more.

Innovative Human Machine Interface (HMI) solutions open up new possibilities for the system integrator. A well implemented touch interface can be much simpler to use than a conventional mechanical button-based interface because it can show the user only those controls that are relevant to a particular operation, while all the controls in a conventional interface are always present.

The GLASS DISPLAY CONTROL, or GDC, allows control of brightness and menu options through projected switches under the glass. Integrators can build software to work with our API to control menu, brightness and other features. This model is delivered with a factory mounted Projected Capacitive Touch Screen (Multitouch, USB interface), Optical Bonding Technology, Solid State Fanless Construction - No Moving Parts, Embedded light sensor, Buzzer and Aluminum Chassis with Glass Front as standard. Brightness is dimmable from 0-100%.

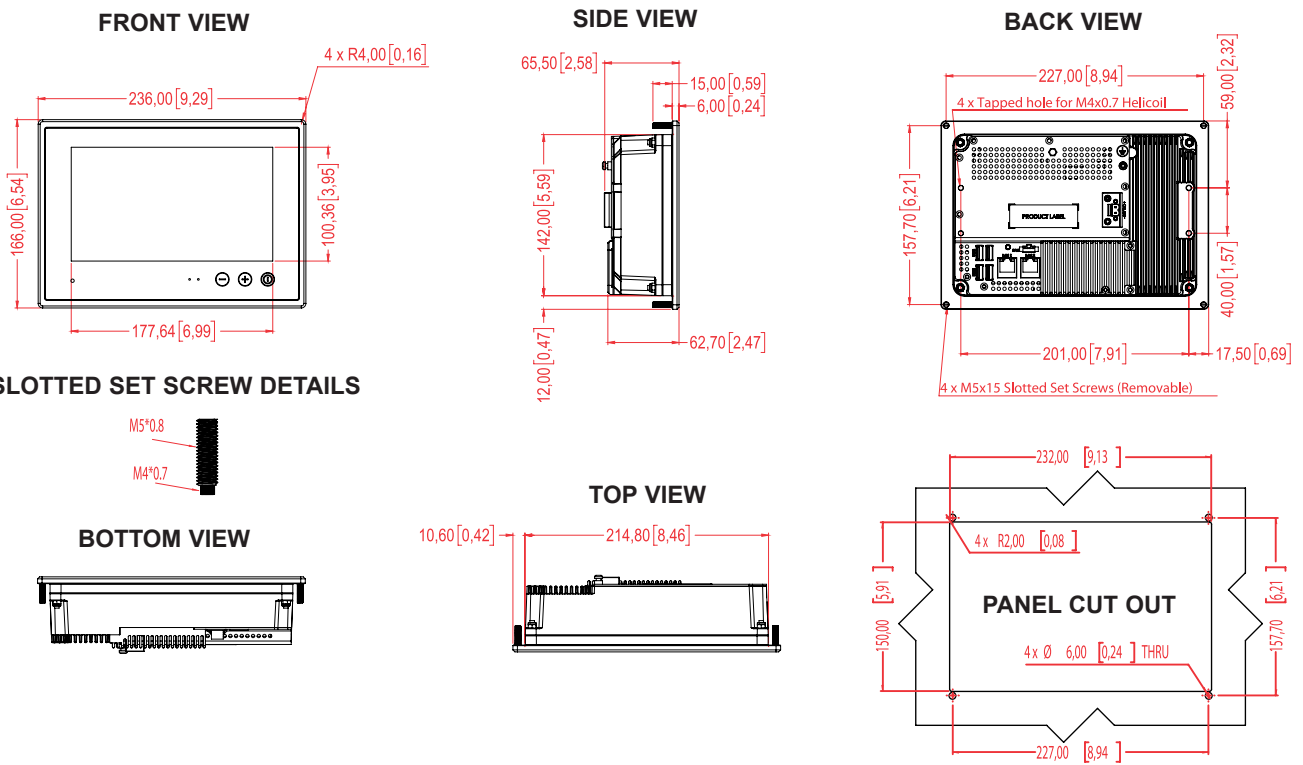

With HD FAN SX2-A1 (External Fan) Accessory - Note: Variant of model illustration shown below

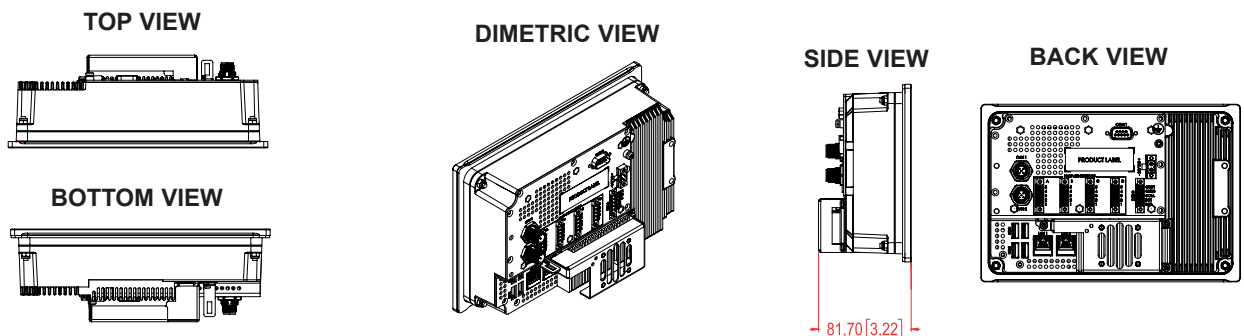

Dimensions might be shown with or without decimals and indicated as mm [inches]. Tolerance on drawings is +/- 1mm. For accurate measurements, check relevant DWG file.

TFT Technology:

- 8.0 inch TFT Liquid Crystal Display module, IPS (in-plane-switching)
- a-si TFT Active Matrix
- Widescreen, Aspect Ratio 16:9
- LED Backlight Technology

TFT Characteristics:

- Native Resolution : 1280 x 720 (HD)
- Pixel Pitch (RGB) : 0.138 (H) x 0.138 (V) mm
- Response Time : 20ms (typ) (Tr+Tf)
- Contrast Ratio : 1000:1 (typ)
- Light Intensity : 680 cd/m² (typ)
- Viewable Angle : 85 deg. (up/down/left/right) (typical)
- Active Display Area : 176.64 (H) x 99.36 (V) mm
- Max Colors : 16.7 million (24bit)

Computer Specifications:

- Supported OS : See table below
- CPU/Processor : 1 x Intel Atom® x5-E3930 Processor, 2M Cache, 1.30GHz / 1.80GHz
- Installed Storage : 1 x 32GB eMMC (Default) or see table below for additional options
- Installed Memory : 1 x 2GB DDR3L single channel (default) or see table below for additional options
- System Chipset : Intel® SOC
- Graphics Chipset : Intel® HD Graphics 500 (CPU dependent)
- Ethernet LAN #1 : Intel® i210IT PCI-E Gigabit LAN 10/100/1000Mbps
- Ethernet LAN #2 : Realtek RTL8111G PCI-e Gigabit LAN 10/100/1000Mbps
- BIOS : AMI BIOS, supports ACPI
Note: "Legacy Mode" option is not fully supported for System Chipset and Microsoft® Windows® 10.
- Buzzer : Yes (according to EN60945)
- Speaker : None
- WatchDog Timer : Yes (256 segments, 0, 1, 2...255 sec/min)
- Other features : RTC (0.5s/day*), Battery Alarm, TPM2.0, GPIO, WakeOnLan, Fast Boot, AT mode, USB Boot

Native 1:1 resolution recommended is 1280 x 720 @ 60 Hz.

*Required accuracy may be dependent of the actual implementation/environment and may require calibration to be within specified boundaries.

Power Specifications:

Power Supply:

- 12-24VDC Nominal

Power Consumption:

- Operating : 17W (typ) - 50W (max)

Available Computer Configurations:

Type	Description	Size/Specification
Memory	DDR3L SO-DIMM	- 2GB Single Channel - 4GB Dual Channel - 8GB Dual Channel

Additional Internal Storage:

Storage	SSD m.2 SATA	- 240GB ->
	eMMC	- 32GB, 128GB

Software Support	Application Programming Interface (API) - as defined in associated documents	- SCOM
------------------	--	--------

OS Options	Windows® 10 IoT Enterprise 2019 LTSC (64bit) (Product Distribution End Date January 2029) or Linux (Apollo Lake: use kernel 4.10 or later).	
------------	---	--

Physical Dimensions:

- W:236.00 [9.29"] x H:166.00 [6.54"] x D:62.70 [2.47"] mm [inch]
- Built-in Console mounting 4 x M5x15mm screws
- Weight approx: 1.9kg / 4.2lbs

Product Carton Size and Weight:

- L:320.00 [12.60"] x W:180.00 [7.09"] x H:320.00 [12.60"] mm [inch]
- Approx. 3.0kg / 6.6lbs

User Controls:

Behind front bezel - Glass Display Control™ (GDC) IP66:

- 3 x Configurable buttons, Status RGB LED,
- Buzzer (through glass) (75-85dB), Light Sensor (behind glass)

Environmental Considerations:

• Operating	: Temperature -15°C to +55°C
	: Temperature -20°C to +70°C (HD FAN SX2-A1)
• Storage	: Temperature -20°C to +60°C
• Humidity	: Up to 95% (Operating / Storage)
• Shock - Vibration	: 5g/11ms - 0.7g (IEC 60945 / IACS E10)
• Air Pressure Maximum Altitude	: Operating: 4000m - Storage: 12912m
• Air Pressure Maximum Altitude (Bonded)	: Operating: 3000m - Storage: 3000m
• IP-Rating Protection	: Protection: IP66 front, IP20 rear (EN60529)
• Compass Safe Distance	: Standard: 65cm - Steering: 25cm
• Vibration	: On engine 4grms

Lifetime Considerations:

Even though the test conditions for bridge units provide for a maximum operating temperature of 55°C, continuous operation of all electronic components should, if possible, take place at ambient temperatures of only 25°C. This is a necessary prerequisite for long life and low service costs.

Input/Output Interfaces:

• USB2.0 (<5m)	: 2 x USB Type A (4-pin)
• USB3.0 (<3m)	: 2 x USB Type A (9-pin)
• Ethernet GbLan	: 2 x RJ45
• COM RS-232 (Internal)	: 1 x Internal Virtual COM (Software controlled)
• DC Power Input	: 1 x 2-pin Terminal Block 5.08
• External Fan	: 1 x 4-pin, 292254-4 connector (for optional fan)

Factory Defaults:

- Projected Capacitive Touch Screen (Multitouch, USB interface)
- Optical Bonding Technology
- AG Coated Front Glass
- USB-C-24: Dust Covers for USB
- PJC-45: Dust Covers for RJ45 ports
- HD KIT USB-A1: USB Cable Support Bracket
- P023456: IP66 Mount Gasket (EPDM), Flush/Console mount

Factory Options:

- IP22 (EN60529) Model : HD 08T30 MMC 2xx-xxxSAx
- With HD IO-Board : HD 08T30 MMC 2xx-xxxxHx
- Variations of CPU/Processor, Storage, RAM/Memory and Operating System
- ATEX C1D2 and UL certification

Available Accessories:

- HD TMB SX2-A4 : 1 x Table/Ceiling Mount Bracket. Not EN60945 Tested
- HD VED SX2-L1 : 1 x VESA Adapter (75/75, 100/100). Not EN60945 Tested
- HD FAN SX2-A1 : 1 x 40x40cm. -20°C to +70°C
Max speed 7000 rpm +/- 15%
- HD WBK SX1-A3 : 1 x Wallmount Box, not EN60945 Tested
- JH C01MF A-A : 1 x USB Cable 1m, TypeA-Chassis mount receptacle
- P023456 : 1 x IP66 Mount Gasket (EPDM), Flush/Console mount
- HT 00262 OPT-A1 : 4 x RS-422/RS-485 isolated, USB ext. module
- HT 00263 OPT-A1 : 4 x RS-232 COM non-isolated, USB ext. module
- HT 00264 OPT-A1 : 1 x CAN isolated, 2 channel, USB ext. module
- HT 00264 OPT-A2 : 1 x CAN isolated, 2 channel, socketCAN USB ext. module
- HT 00273 OPT-A1 : 4 x Digital IN/OUT isolated, USB ext. module
- HT 00274 OPT-A1 : 2 x LAN 10/100Mbps, RJ45, USB ext. module

Please see user manual/datasheet/drawings for more information

APPROVALS & CERTIFICATES

This product have been tested / type approved by the following classification societies:

IEC 60945 4th (EN 60945:2002)

IACS E10

EU RO MR - Mutual Recognition

ClassNK - Nippon Kaiji Kyokai

CCS - China Classification Society

KR - Korean Register of Shipping

BV - Bureau Veritas