

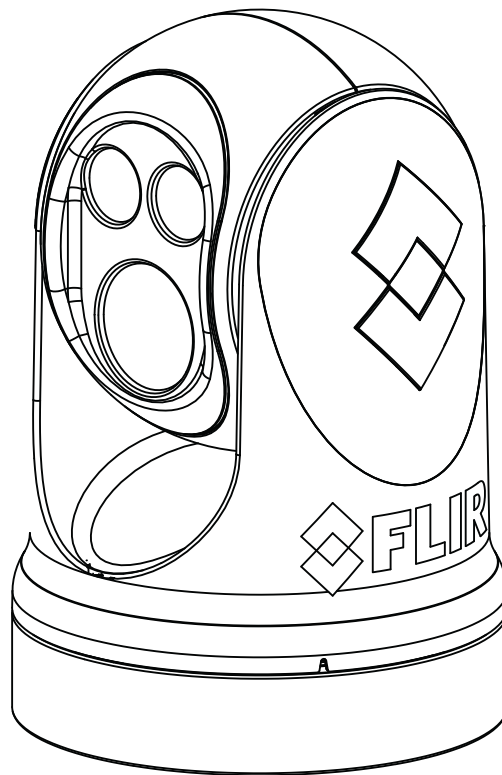

Installation Guide

M400



© 2020 FLIR Systems, Inc. All rights reserved worldwide. No parts of this manual, in whole or in part, may be copied, photocopied, translated, or transmitted to any electronic medium or machine readable form without the prior written permission of FLIR Systems, Inc.

This document does not contain export-controlled information

Names and marks appearing on the products herein are either registered trademarks or trademarks of FLIR Systems, Inc. and/or its subsidiaries. All other trademarks, trade names, or company names referenced herein are used for identification only and are the property of their respective owners.

This product is protected by patents, design patents, patents pending, or design patents pending.

The contents of this document are subject to change.

FLIR Systems, Inc.

6769 Hollister Avenue

Goleta, CA 93117

Phone: 888.747.FLIR (888.747.3547)

maritimecamerasupport@flir.com

Proper Disposal of Electrical and Electronic Equipment (EEE)



The European Union (EU) has enacted Waste Electrical and Electronic Equipment Directive 2002/96/EC (WEEE), which aims to prevent EEE waste from arising; to encourage reuse, recycling, and recovery of EEE waste; and to promote environmental responsibility.

In accordance with these regulations, all EEE products labeled with the “crossed out wheeled bin” either on the product itself or in the product literature must not be disposed of in regular rubbish bins, mixed with regular household or other commercial waste, or by other regular municipal waste collection means. Instead, and in order to prevent possible harm to the environment or human health, all EEE products (including any cables that came with the product) should be responsibly discarded or recycled.

To identify a responsible disposal method where you live, please contact your local waste collection or recycling service, your original place of purchase or product supplier, or the responsible government authority in your area. Business users should contact their supplier or refer to their purchase contract.

Contents

Installing the M400	
General Information	5
Standard Features	5
Additional Installation Components	6
Additional References	6
Warnings and Cautions	7
Installation Overview	8
General Location Considerations	10
System Installation	11
Installing the Joystick Control Unit (JCU II)	12
Electrical Connections	15
Connecting Power	15
Proper Grounding	16
Video Connections	16
Ethernet Connections	16
Installation Examples	
Basic Standard Installation	17
Video Streams	17
Digital Video and PC Interface	18
FLIR DNR400-Series Connection	18
Installation of other Shipboard Systems	19
NMEA 0180 Interface	19
M400 Reference	
M400 Maintenance	20
Cleaning the JCU II	20
Cleaning the Camera Optics	20
Cleaning the Camera Body	20
Specifications	21
External Standards	22
Acronyms	23

Mechanical ICD Reference

M400 Top Down Riser Installation Template	28
M400 Interface Control Document	33
Joystick Control Unit Interface Control Document	34
Maritime/Tracker Joystick Control Unit Interface Control Document.....	35
M400 Riser Installation Document	36

Installing the M400

General Information

This manual describes the installation of the M400 system. If you need help or have additional questions, please call to speak with our support experts; see the phone numbers on the back cover of this manual.

The multi-sensor M400 is a stabilized maritime thermal and visible-light camera system for use on most types of vessels. Its state-of-the-art long wave infrared (LWIR) thermal camera provides excellent nighttime visibility and situational awareness, without any form of natural or artificial illumination. The HD visible-light camera with 30X optical zoom provides daytime viewing.



M400 Pan/Tilt Camera System

Standard Features

- Pan/Tilt provides continuous 360° pan and +/- 90° tilt.
- Active gyro-stabilization provides steady, long-range viewing.
- Video tracking locks on and follows objects as long as they are in view (M400XR only).
- Firefighter mode provides user-adjustable colored temperature bands to aid in identifying hot spots that may be visually obscured by smoke (M400XR only).
- High intensity LED spotlight

General Information

The M400 should be installed by a qualified marine electronics technician; incorrect installation could void the warranty.

This manual includes information about the following topics:

- Installation overview and planning
- Mounting the camera and installing the Joystick Control Unit (JCU II)
- Connecting the electronics
- Configuration and Communication using a PC
- Maintaining the camera
- Parts list and other reference information



Additional Installation Components

Contact FLIR Systems, Inc. for more information regarding available accessories including additional JCU IIs, PoE equipment, video distribution amplifiers, Serial to Ethernet servers, NMEA Multiplexers, etc.

Additional References

Your M400 camera comes with a complete documentation set available from the FLIR Systems, Inc. Web site. All documents are in PDF format and can be viewed with Adobe Acrobat Reader:

- *M400 Operator's Manual* (FLIR Doc. # 432-0012-02-10) contains information about how to configure and operate the camera.
- M400 Quick Start Guide (FLIR Doc. # 432-0012-02-11) is a card used as a reference for the functions executed by the various JCU II buttons.
- ICD (FLIR Doc. # 432-0012-XX-41) is an Interface Description Document providing detailed installation information.

For safety, and to achieve the highest levels of performance from the M400 system, always follow the warnings and cautions in this manual when handling and operating the M400 camera system.

Warning notices are used to emphasize conditions that could cause personal injury or death existing with this equipment, or that may be associated with its use.

Caution notices are used where equipment might be damaged if care is not taken or an operation might have an unexpected outcome.

Notes call attention to information significant to understanding and operating the equipment.

Warnings and Cautions

Warning: Do not use the M400 imaging system as the primary navigation system. Use it in conjunction with other navigation aids and a primary manual navigation system.

Warning: Ensure power is removed before accessing power wires during installation or removal of system components. DO NOT HOT SWAP components (such as the JCU II). Damage to equipment or injury to personnel may result.

Warning: The M400 system is not designed to operate in an enclosed environment in the presence of flammable gases. Failure to follow this warning may result in explosion or fire.

Warning: Use of insufficient wire gauge can result in fire.

Warning: The M400 camera body is a remotely and automatically controlled device. Ensure camera motion has been disabled before cleaning surfaces that can cause pinch hazards.

Caution: Do not open the M400 camera unit for any reason. Disassembly of the camera (including removal of the cover) can cause permanent damage and will void the warranty.

Caution: Be careful not to leave fingerprints on the M400 camera optics.

Caution: The M400 requires a power supply of 12 Vdc to 24 Vdc nominal, 5.5 A maximum @ 24 Vdc, 11 A maximum @ 12 Vdc. Absolute voltage range: 12 Vdc to 32 Vdc. Operating the camera outside of the specified input voltage range or the specified operating temperature range can cause permanent damage.

Operating temperature range	-20 °C to +55 °C (-4 °F to +131 °F) per IEC 60945
Storage temperature range	-50 °C to +80 °C (-58 °F to +176 °F)

Caution: During installation, ensure the cables exiting the camera are not in contact with sharp edges, do not bend at sharp angles, and are not pinched between the bottom of the camera and the mounting surface. Do not pull on the cables with excessive force.

Installation Overview

The M400 includes these standard components:



The standard cable set shipped with the M400 system is shown below in Figure 1-1. See “[M400 Interface Control Document](#)” on page 33 for the location of cable connections on the bottom of the M400 camera.

Contact FLIR Systems, Inc. for information on additional cables, shown in Table 1.1, which may be purchased.

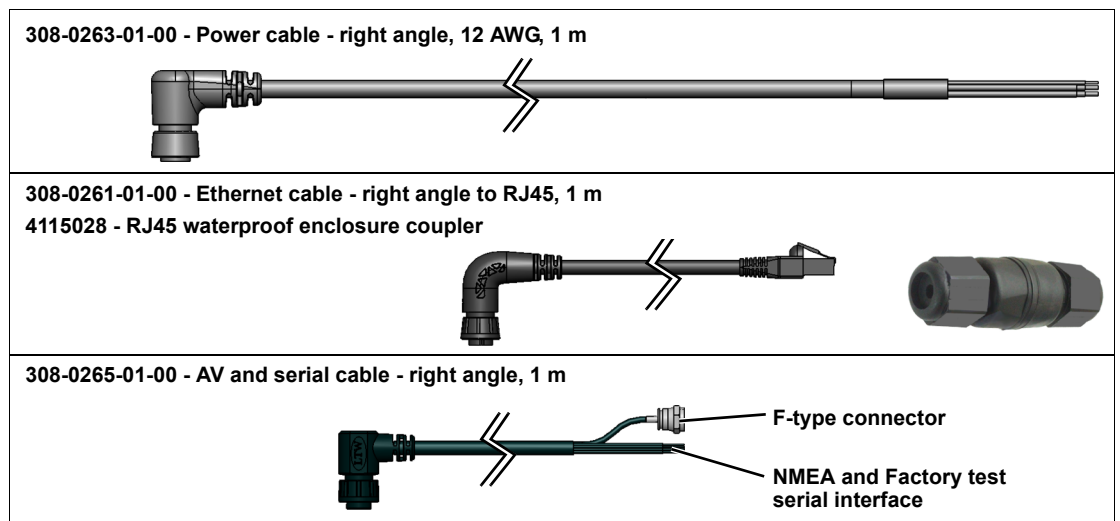

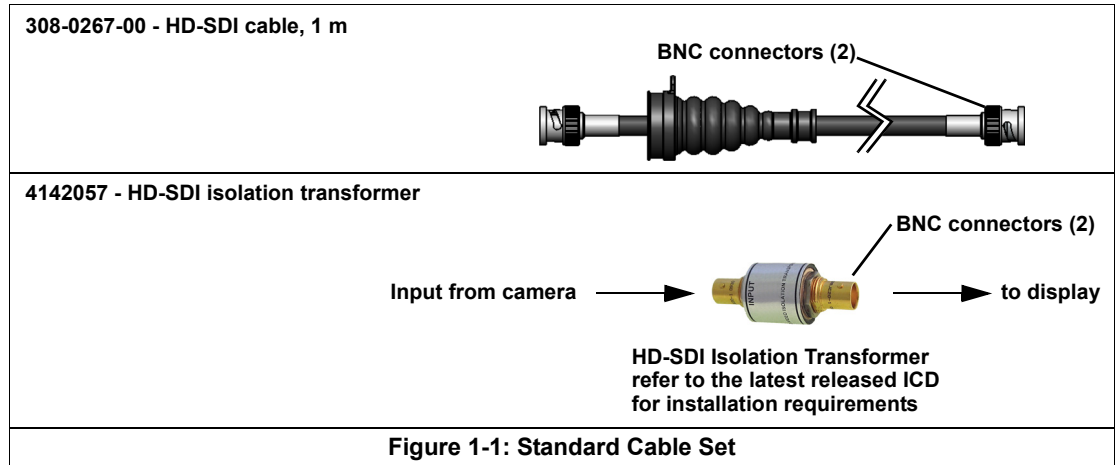
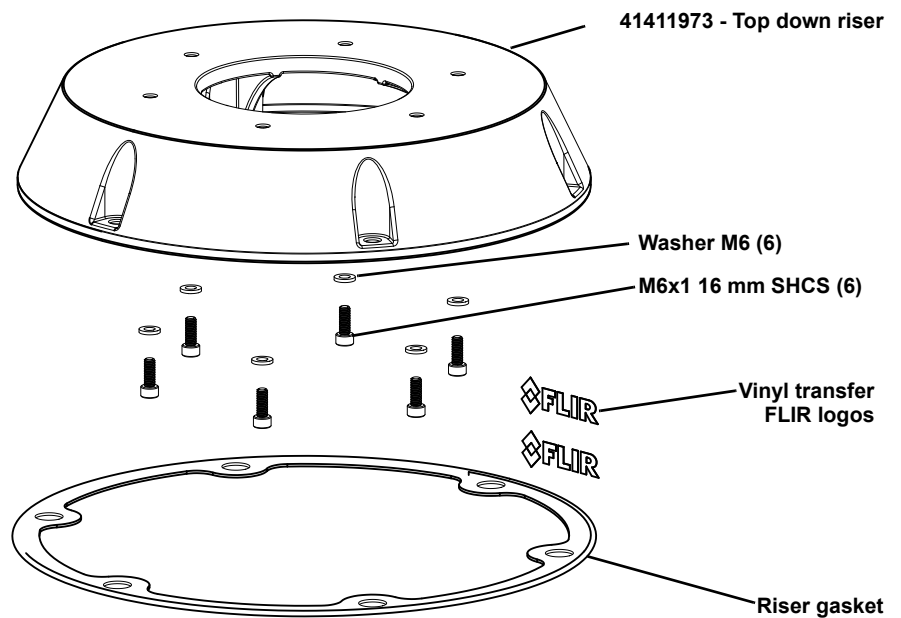

TABLE 1.1 Additional Cables Available from FLIR

Part Number	Description
308-0260-01-00	Cable - Ethernet to RJ45, 1 m
308-0262-01-00	Power Cable - 12 AWG, 1 m
308-0264-01-00	Cable - AV and serial, 1 m
4141864	Cable - HD/SDI, 100 ft
308-0251-30-00	Cable - Ethernet to RJ45, 100 ft, LSZH
308-0252-30-00	Cable - Ethernet, RA to RJ45, 100 ft, LSZH
308-0253-30-00	Cable - Power, 12 AWG, 100 ft, LSZH
308-0254-30-00	Cable - Power, right angle, 12 AWG, 100 ft, LSZH
308-0255-30-00	Cable - AV and serial, 100 ft, LSZH
308-0256-30-00	Cable - AV and serial right angle, 100 ft, LSZH



You will need to supply the following items depending on planned installation:

- For Top Down Riser—Six (6) M8 stainless steel bolts and washers to secure the top down riser after the camera is attached—bolt length depends on mounting platform thickness.
Recommended:
M8 socket head cap screws, or
5/16" - 18 socket head cap screws, or
5/16" - 18 hex head sheet metal screws type 316 stainless steel
Apply thread locker (Loctite 262 or equivalent)
- One or more multi-function displays (MFD) or other analog or digital video display devices
- Coaxial RG6 video cable to customer-supplied analog video monitors
- Coaxial RG6 video cable to customer-supplied HD-SDI digital video monitors
- Ethernet cables to connect the M400 and the JCU II to the PoE Ethernet switch, 8-conductor T568B
- Ethernet cables to connect to the ship's Ethernet port, 8-conductor T568B
- Miscellaneous electrical hardware, connectors, and tools

General Location Considerations

Warning: The M400 system is not designed to operate in an enclosed environment in the presence of flammable gases. Failure to follow this warning may result in explosion or fire.

First determine a good location for mounting the M400 system body and the JCU II. The system has four cable connections:

- Power
- Ethernet connection to PoE switch for the JCU II; the switch requires an Ethernet connection to the JCU II and optionally to other JCU II controllers or to a shipboard network.
- HD-SDI digital video
- Composite analog video and serial data (NMEA and factory test)

More than one JCU II can be installed to control the camera and more than one display can be used to view the video. Also, a single JCU II can be used to control more than one camera. Most often, the JCU II and video monitor are mounted close together, as a pair, so the video can be viewed when the camera position (pan, tilt, zoom) is changed with the JCU II.

When determining the component locations, consider how the system may be expanded in the future. For example, adding an additional monitor, or perhaps a JCU II and monitor pair.

Consider the following points when determining the camera location:

- Mount the M400 camera body as high as practical, but without interfering with any radar, navigational, or communications electronics.
- To minimize interference with video signals, the camera body must be mounted a minimum of 1 meter away from any radio frequency antenna.
- Minimize the degree to which vessel structures block the camera's 360° view. The camera's continuous-pan design lets it rotate and point in all directions.

System Installation

- It is a good practice to test the unit at the planned installation location with typical vessel electronics active prior to mounting the camera.
- Mount the camera as close to the vessel's center line as possible so you will have a symmetrical view of on-coming traffic, obstacles, and other navigational hazards.
- The M400 camera has a "forward" direction adjustment which has been set at the factory. This is the direction directly toward the front of the vessel. Icons on the video show the direction the camera is facing in relation to an outline of a ship. Refer to the latest Interface Description Document for details. After installation, the forward direction of the camera must be verified and adjusted if required. Refer to *M400 Operator's Manual* (FLIR Doc. # 432-0012-00-10).



Note: When the camera is mounted upside down (ball down), the camera base must be rotated backwards, to point toward the stern of the vessel.

- An appropriate camera mount suited for the camera mass and potential vibration and mechanical shock is important for proper camera functioning. The camera is tested to hold position for mechanical shock up to 9 G transverse and 15 G vertical. Improper mounts that are loose and/or resonate can magnify vessel impacts causing the camera to be unable to maintain pointing direction.
- When selecting a mounting location for the M400 system, consider cable lengths and cable routing. Ensure the cables are long enough, given the proposed mounting locations and cable routing requirements, and route the cables before you install the components.
- Use power cables that have sufficient dimensions to ensure safety and video and communication cables that have sufficient dimensions to ensure adequate signal strength.
- To ensure a proper seal between the camera unit and the vessel, an O-ring should be installed in the camera base. The O-ring will seal properly with a surface that is flat to within 1.5 mm (0.06 in) over the diameter of the base of the camera. If it is necessary to install on a surface that does not meet this criteria, a marine-grade sealant (3M 4200 or equivalent) must be used rather than the O-ring.
- A final location consideration is the relation between the camera and other navigation devices. If relying on a magnetic compass for navigation and direction, establish a "compass safe distance" for any object placed in its vicinity, especially any electronic equipment. The magnetic compass safe distance for the camera is 40 cm (15.7 in).

System Installation

In most installations, the M400 is mounted upright on top of a mounting surface, with the pan/tilt base below the camera; this is known as the ball up orientation. Optionally, the unit can be hung upside down or ball down. Once the mounting location has been selected, verify that both sides of the mounting surface are accessible. The camera mounting surface must be at least as large as the footprint of the camera itself to ensure an adequate seal with the O-ring.

Use a thread-locking compound such as Loctite 262 or equivalent with all metal-to-metal threaded connections.

Caution: Use all six mounting holes to secure the camera rigidly.

As an alternative to a mounting O-ring, you can use a marine-grade sealant such as 3M 4200 or the equivalent.

Mounting Upright

The cable connectors terminating the pigtail cables on the camera are waterproof, vibration tolerant, twist pin connectors designed for the marine environment. Appropriate sealing steps are needed when making connections to on-board systems.

Caution: If you print the template from the PDF file, ensure that it is printed to the correct scale by checking the dimensions prior to cutting any holes.

Using the template as a guide, mark the location of the holes for mounting the camera

Once the holes are drilled in the mounting surface, thread the power supply, video, and Ethernet cables from the camera through the center hole, and then place the camera on the mounting surface so the mounting bolts extend through the drilled holes. Secure and seal the camera body to the mounting surface.

Mounting Upside Down

When a camera is going to be mounted upside down (ball down), a menu setting is used to configure the system for ball down operation. Set the camera orientation after the camera the camera is installed. Refer to *M400 Operator's Manual*.

Installing the Joystick Control Unit (JCU II)

Mount the JCU II in an area that is close to the monitor being used to display the M400 video output. Make sure the area you choose leaves enough room for the cable under the JCU II. The magnetic compass safe distance from the JCU II is 55 cm (21.7 in).

The JCU II can be mounted to the dash in any orientation, using four captive mounting screws that hold panel mounting clamps. When the mounting screws are tightened, the panel mounting clamps rotate and extend away from the JCU II at a right angle, and come into contact with the mounting surface. The JCU II can be mounted to dash thicknesses ranging from 0.16 cm to 4.45 cm (0.063 in to 1.750 in). A trim bezel snaps on top of the JCU II to cover the mounting screws. See [“Installing the Joystick Control Unit \(JCU II\)”](#) on page 12 for detailed instructions.

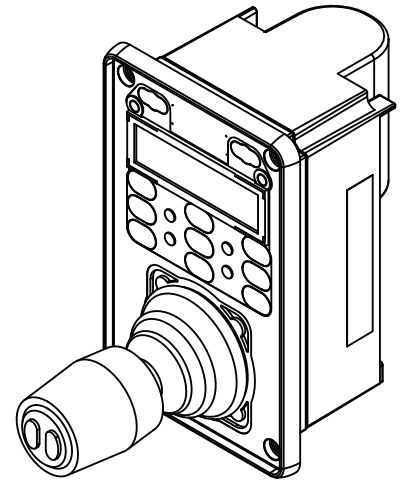

Joystick Control Unit

JCU II Connection to Camera

The JCU II is a Power over Ethernet (PoE) device and can be connected to either the supplied PoE Ethernet Switch or a customer supplied PoE injector.

To ensure a proper seal around the JCU II, the supplied gasket must be applied to the JCU II and the cutout opening for the JCU II should precisely match the template. If the cutout opening is too large, the gasket around the JCU II may not cover the opening adequately.

The cable gland seal is designed for use with double-shielded category 5 Ethernet cable. To ensure a good seal and to maintain compliance with EMI ratings, a double-shielded cable is required.

Caution: If you print the template from the PDF file, ensure that it was printed to the correct scale by checking the dimensions prior to cutting any holes.

Standard JCU II Mounting Instructions

1. Using the JCU II template supplied as a guide, mark the location of the rectangular opening that will allow the JCU II to be recessed in the vessel's control console. Ensure the corners are marked precisely and cut square.
2. Apply the adhesive side of the rubber gasket to the back of the JCU II on the surface that faces the mounting platform. The JCU II comes with 4 panel mounting clamps that can be reversed when the thickness of the panel material is less than 7.9 mm (5/16 or 0.31 in); see instructions below. Ensure the mounting clamps are rotated inward and are recessed so the entire JCU II fits into the hole.
3. Remove boots from both ends of the Ethernet cable, as it may interfere with the coupling gland. The boot may cause the RJ45 connector tab to depress, which can lead to intermittent connections.
4. Loosen or remove the cable gland nut on the JCU II, and insert the Ethernet cable RJ45 connector through the gland nut. Once the Ethernet cable is connected to the JCU II, replace the gland nut and turn the nut 1/4 turn beyond hand tight.
5. Insert the JCU II into the hole and secure with the 4 corner screws. Rotate each screw one full turn and ensure the mounting clamps are rotated outward from the JCU II housing. Tighten the screws to draw the mounting clamps up against the mounting surface and then tighten another quarter or half turn. Do not over tighten the screws.

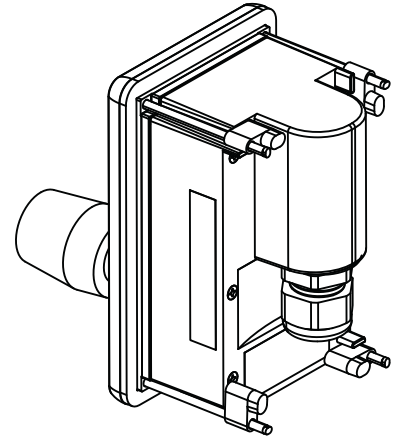
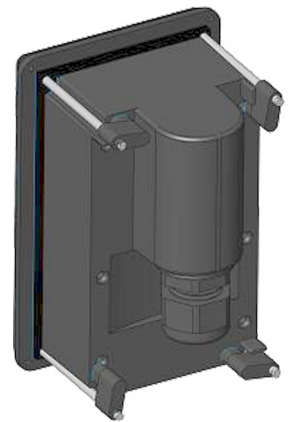
**Joystick Control Unit - Back**

Mounting the JCU II to a Thin Panel

As shipped from the factory, the JCU II can be mounted to dash thicknesses ranging from 7.9 mm to 44.5 mm (0.31 in to 1.75 in). The clamps are set with the small foot on each clamp facing away from the panel, as shown.

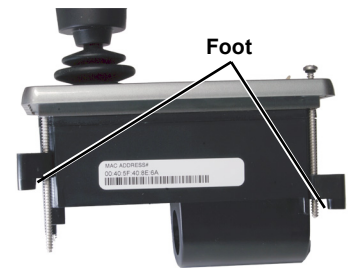

Foot
Panel thickness up to 44.5 mm

If you intend to mount the JCU II to a panel of 7.9 mm (0.31 in) thickness or less, remove the clamps from the mounting screws, turn them around and thread them back onto each of the four screws. The foot on each clamp now faces the panel and allows the clamp to contact thinner panel surfaces while still allowing for proper compression of the JCU II mounting gasket to form a watertight seal.



Foot
Panel thickness less than 7.9 mm

Mounting the JCU II Key Pad Front Cover

Note: The JCU II is shipped without the front cover installed. The face of the JCU II has an adhesive layer, covered by a removable film, to secure the front cover after the JCU II is installed in its final location.

1. Pull up the tab to remove the adhesive protection film and expose the adhesive layer.
2. Install the key pad front cover over the joystick ensuring that the joystick boot is not caught between the cover and the JCU II.
3. Position the cover starting with the bottom corners and then press into the adhesive on all edges. The cover should snap into place flush with the JCU II bezel.



Electrical Connections

Watertight connectors/enclosures should be used on each of the electrical connections. Table 1.2 describes the connections for the cables attached to the camera.

Warning: Ensure power is removed before accessing power wires during installation or removal of system components. Damage to equipment or injury to personnel may result.

Caution: During installation, ensure the cables exiting the bottom of the camera are not in contact with sharp edges, do not bend at sharp angles, and are not pinched between the bottom of the camera and the mounting surface. Do not pull on the cables with excessive force.

Caution: It is recommended that any built-up triboelectric charge on the Ethernet cable should be discharged *before* connecting it to the JCU II and camera. This can be accomplished simply by pressing an ungloved finger across the Ethernet RJ45 connector of the cable for a few seconds.

TABLE 1.2 Connections Quick Reference

Cable Label	Connectors	Comment
Power	Red	Nominal 24 Vdc Absolute range 12 Vdc to 32 Vdc 2.5 A typical, 5.5 A max maximum @ 24 Vdc; 5 A typical, 11 A max maximum @ 12 Vdc
	Black	Vdc return
	Drain	Chassis ground
HD/SDI	BNC style Coax	Digital video with isolation
Analog Video and serial cable	F-type style Coax and pigtail for serial (NMEA/factory test)	Analog video
Ethernet	RJ45	Use shielded Ethernet cable for connection to PoE switch providing power to JCU II and optional connection to shipboard network.

Connecting Power

The camera itself does not have an on/off switch. Generally the camera will be connected to a circuit breaker and the circuit breaker will be used to apply or remove power to the camera. When power is supplied, the camera will be in one of three modes: Booting Up, Standby, Parked, or Powered On. The M400 *Operator's Manual* has detailed information about powering and operating the camera.

Installation of a circuit breaker (or fuse) in line with the power connection is required to protect the power wiring and camera from power surge or short circuit.

TABLE 1.3 Fuse Recommendation

Model	Fuse
M400	12 amp, slow blow at lowest voltage range (12 Vdc)

The installer must use power cable wires that are sufficient size gauge or diameter for the supply voltage and total load (camera and length of cable run), to ensure proper supply voltage at the camera and adequate current carrying capacity.

Electrical Connections

Warning: Use of insufficient wire gauge can result in fire. Wire gauge depends on supply voltage shown. For lower supply voltages, lower gauge wire must be used.

TABLE 1 4. Typical Power Cable Wire Gauge

Length in Meters (Feet)	Wire Gauge (AWG) for 12V Supply	Wire Gauge (AWG) for 24V Supply
8 (25)	16	18
16 (50)	14	18
24 (75)	12	16
32 (100)	10	16

Proper Grounding

Caution: Ensure the camera is properly grounded. Following best grounding practices, the camera chassis ground should use the lowest resistance path possible.

Failure to provide this connection may result in electrical interference between camera and other shipboard electronic systems. Furthermore, it is recommended that a bonded grounding scheme is used with a common ground between the chassis ground and electrical return, with the connection made as close as possible to the negative terminal of the battery.

Video Connections

Video cables of various lengths with different connectors at one end are available from FLIR. The video cable used should be rated as RG6 to ensure an adequate quality video signal. For cable runs in excess of 100 ft, a video amplifier should be used.

Ethernet Connections

The Ethernet cable from the camera can be connected to another Ethernet cable with an RJ45 waterproof enclosure connector (FLIR PN 4115028). The Ethernet network cable should be 8-conductor T568B, Ethernet, double-shielded for EMI considerations.

Installation Examples

This chapter describes several typical installations using standard and optional accessories.

Basic Standard Installation

The JCU II selects which video output to view (IR or visible) on the monitor and to control the camera configuration using the OSD menus. If two JCU II are used (see Figure 2-2), typically, they are installed in different locations aboard the vessel, each with a monitor. They both can be switched on and enabled at the same time. The video to the monitor can be either the HD-SDI video signal or the composite analog video signal to match the customer supplied monitor. NMEA/serial data connections and digital IP video connections are not shown below.

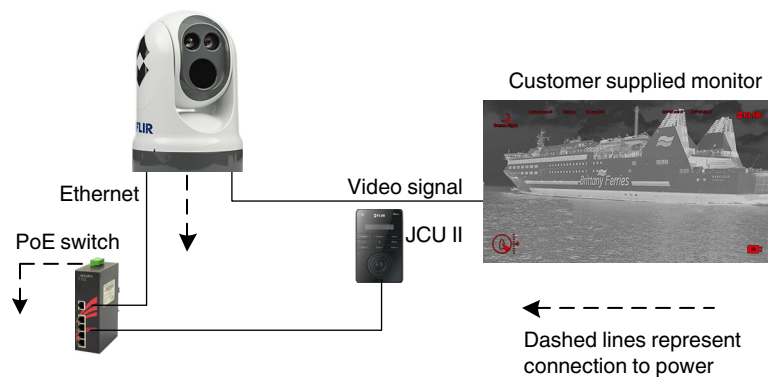

Figure 2-1: Basic System

Video Streams

The M400 system provides five configurable video outputs.

Two video streams are provided on separate connectors:

- one analog composite video
- one HD-SDI digital video

Both video streams are configurable using the camera Web Server to show video from the active camera, the secondary camera, or to always show video from one or the other.

Three digital video streams are provided over the Ethernet connector:

- VIDEO_0 always shows the DLTV visible stream (HD res)
- VIDEO_2 always shows the IR stream (HD res)
- VIDEO_4 always shows Live View (low res) video on the camera Web Server page configurable to show the active camera, the secondary camera, or to always show video from one or the other.

Digital Video and PC Interface

A computer (PC) on the network can control and configure the camera using a web browser (see *M400 Operator's Manual*). Additionally, both IR and DLTV digital video streams are available on the Ethernet connection to a shipboard network for use by a video management system (VMS) or a network video recorder (for example, FLIR DNR400 Series) to record video streams and provide other features such as video storage and backup. Refer to the documentation for the VMS or video recorder for operation and setup details.

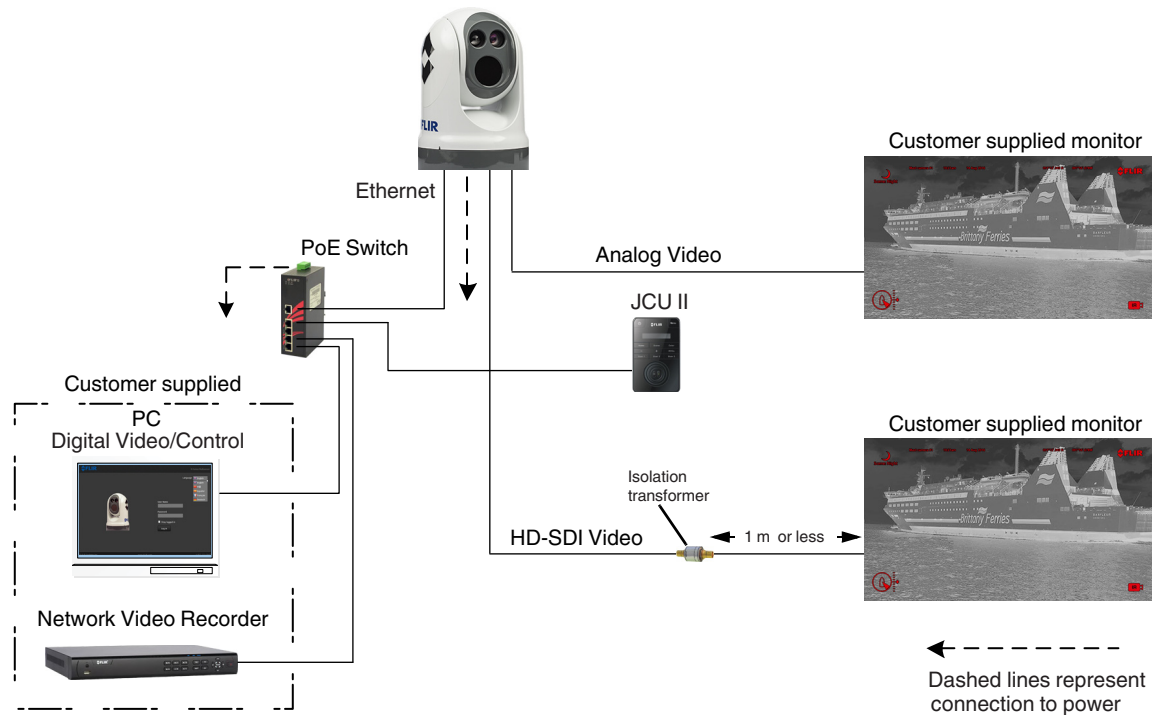



Figure 2-2: System with Video Recorder

FLIR DNR400-Series Connection

1. Open a web browser and enter the camera IP address to log in with the **admin** user name.
2. Ensure that the VMS Remote INTERFACE 1 driver (ONVIF v2.0) is enabled. Refer to *M400 Operator's Manual*.
3. Connect the camera Ethernet to the switch, as shown in Figure 2-2.
4. Connect the video recorder on the same Ethernet network.

The DNR400 video recorder must be connected to the Internet to utilize  services.

5. Follow the instructions in the VMS or video recorder documentation to discover the camera.

Installation of other Shipboard Systems

NMEA 0180 Interface

Serial NMEA 0183 interface devices (radar interface for example) can be connected via a Serial port into the M400 system. The NMEA serial interface is included as pigtail leads on the composite analog video/serial cable.

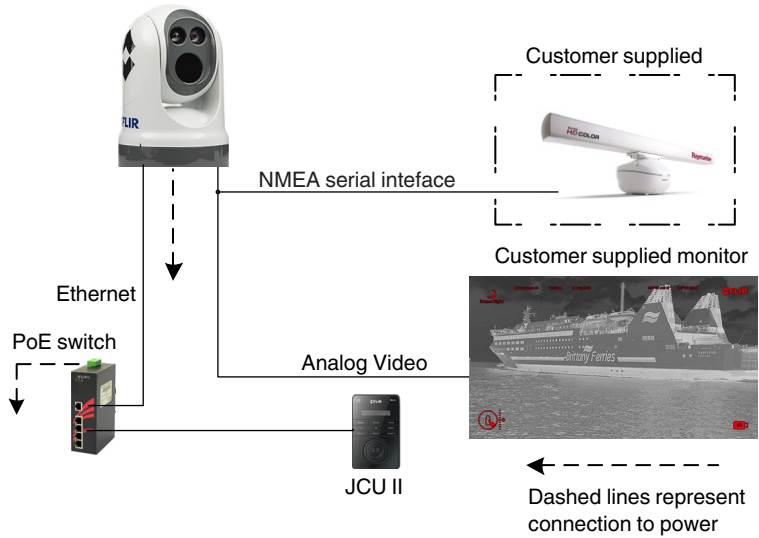

Figure 2-3: Shipboard System

M400 Reference

M400 Maintenance

The M400 components are designed for years of rugged, trouble-free use.

Cleaning the JCU II

To clean the JCU II, use a soft cloth and clean water. Mild household cleaner such as Windex can also be used to remove tougher stains or spots. Do not use alcohol based cleaners or any type of solvents as this may discolor or damage the unit.

Cleaning the Camera Optics

Warning: The M400 camera body is a remotely and automatically controlled device. Ensure camera motion has been disabled before cleaning surfaces that can cause pinch hazards.

Great care should be used with your camera's optics. They are delicate and can be damaged by improper cleaning. The M400 thermal camera lenses are designed for the harsh outdoor environment and have a coating for durability and anti-reflection, but may require cleaning occasionally. FLIR Systems, Inc. suggests that you clean the lens when image quality degradation is noticed or excessive contaminant build-up is seen on the lens.

Rinse the camera housing and optics with low pressure fresh water to remove any salt deposits and to keep it clean. If the front window of the camera gets water spots, wipe it with a clean soft cotton cloth dampened with fresh water. If the window requires further cleaning, use a soft moist cotton-based cloth with Isopropyl alcohol or dish soap.

Do not use abrasive materials, such as paper or scrub brushes as this will possibly damage the lens by scratching it. Only wipe the lens clean when you can visually see contamination on the surface.

Cleaning the Camera Body

Warning: The M400 camera body is a remotely and automatically controlled device. Ensure camera motion has been disabled before cleaning surfaces that can cause pinch hazards.

Caution: The M400 is sealed at the factory against liquid water, suspended particulates, and other contaminants. It is important that you not open the camera for any reason, as it will compromise this seal and possibly damage the unit. Opening the M400 camera will void the manufacturer's warranty.

Do not pressure wash the camera, especially around the FLIR logos, as that could force water through the camera seals. Clean the interface between the yoke and base often to prevent accumulation of debris or salt deposits.

If you have a problem with your thermal camera, do not attempt to repair it yourself. The M400 camera is a sealed unit and can not be opened or serviced in the field. Consult your installation dealer or FLIR Systems, Inc. for repair information.

Specifications

Table 3.1 lists details about physical characteristics, power usage, and environmental features of your M400 camera.

TABLE 3.1 Specifications

Thermal Imaging Specifications	M400
Sensor Type	640 x 480 VOx Microbolometer
Field of View	18° to 6° HFOV / 1.5° HFOV with e-zoom
Focal Length	35 mm (Wide) to 105 mm (Narrow)
E-Zoom	4X Optical Zoom
Imaging Processing	FLIR DDE
Daylight Imaging Specifications	
Detector Type	Long range color daylight and low light viewing
Resolution	High Definition up to 1080/30p
Minimum Illumination	>0.5 lux at 50 IRE / .05 Lux in ICR Mode (B/W)
Zoom	30X Optical Zoom
Focal Length	129 mm to 4.3 mm
Field of View	64° to 2.3° Optical HFOV / 0.2 NFOV e-zoom
Spotlight Specifications	
Type	LED
Lumens	580
Beam	5° Divergence Angle
Physical Characteristics	
Camera Size	32.4 cm (12.75 in) diameter by 46 cm (18.1 in) tall
Camera Weight	12.25 kg (27 lb), depending on the camera model
Joystick Size	9.1 X 14.2 X 8.13 cm (3.6 X 5.6 X 3.2 in) 7.4 cm (3 in) above platform including joystick
Joystick Weight	0.45 kg (1 lb)
Power	
Camera Input Power	24 Vdc, 2.5 A typical, 5.5 A max 12 Vdc, 5 A typical, 11 A max Absolute range 12 Vdc to 32 Vdc
JCU II Input Power	Power over Ethernet (PoE) per IEEE 802.3af
Consumption	50 W Nominal, 132 W maximum

TABLE 3.1 Specifications (Continued)

Environmental	
Operating temperature range	-20 °C to +55 °C (-4 °F to +131 °F) per IEC 60945
Storage temperature range	-50 °C to +80 °C (-58 °F to +176 °F)
Automatic Window defrost	Standard
Sand/dust	IEC 60945
Water Ingress	IP X6
Shock	15 G vertical, 9 G horizontal
Vibration	IEC 60945
Lightening Protection	IEC 60945
Salt Mist	IEC 60945
Wind	100 knot (115 mph)
EMI	IEC 60945

External Standards

Table 3.2 lists other sources of information and standards definitions that may be useful during the installation of your M400 camera.

TABLE 3.2 External References

Standard	Description
IEC 60169-24	Radio-frequency coaxial connectors with screw coupling, typically for use in 75 Ohm cable distribution systems (Type F)
IEC 60754-1	Testing of cable materials indicating content of acidic gases evolved during combustion.
IEC 60945	Maritime navigation and radio communication equipment and systems general requirements
IEC 60529	Degrees of Protection Provided by Enclosures (IPX6)
IEC 60068	Basic Environmental Testing Procedures, Part 2: Tests
89/336/EEC	Electromagnetic Compatibility (EMC) directive
Directive 2002/95/EC	Restriction of the use of certain hazardous substances in electrical and electronic equipment (European Union)
Directive 2002/96/EC	Waste Electrical and Electronic Equipment Reg. 2006
TIA/EIA T568B	CAT5/RJ-45 wiring standard
IEEE 802.3 / IEEE 802.3u	10Base-T/100Base-TX Ethernet
IEEE 802.3af	Power over Ethernet (PoE) standard (48 V/400 mA/15.4 W)
ANSI/SMPTE 170M - 1994	Composite Analog Video Signal (Supersedes RS-170A)
Directive 96/98/EC	Marine Electronics Directive (MED)

Acronyms

Acronym/Term	Definition
AGC	Automatic Gain Control
ANSI	American National Standards Institute
API	Application Programming Interface
B/W	Black and white
DLTV	Daylight TV, used to reference visible-band cameras
EAR	Export Administration Regulations
EMI	Electromagnetic Interference
FFC	Flat Field Correction
FLIR	Forward Looking Infrared
FoV	Field of View
FPS	Frames per Second (refresh rate)
HFoV	Horizontal Field of View
ICD	Interface Control Document
IEC	International Electrotechnical Commission
IEEE	Institute of Electrical and Electronics Engineers
IP	Internet Protocol
IR	Infrared or thermal
JCU II	Joystick Control Unit
LCD	Liquid Crystal Display
LWIR	Long-wave infrared
LSZH	Low Smoke Zero Halogen
MFD	Multifunction display
NMEA	National Marine Electronics Association
NTSC	National Television System Committee
PAL	Phase Alternating Line
P/T	Pan/Tilt
PoE	Power over Ethernet
SCTE	Society of Cable Telecommunications Engineers
SDK	Software Developer's Kit
UPnP	Universal Plug and Play
Vdc	Volts, Direct Current
VIS	Visible (visible-band camera reference)



FLIR Systems, Inc.

CS World Headquarters

FLIR Systems, Inc.
6769 Hollister Ave.
Goleta, CA 93117
USA

PH: +1 888 747 3547, Option 5
maritimecamerasupport@flir.com

Mechanical ICD Reference

The following Mechanical Interface Control Documents detail the outline and mounting for the M400 systems. These documents are provided for reference only. You should consult your local sales representative or application engineer to obtain current ICD information. Also, the Thermal Imaging Camera Data Sheet available from the website contains important mechanical interface data as well.

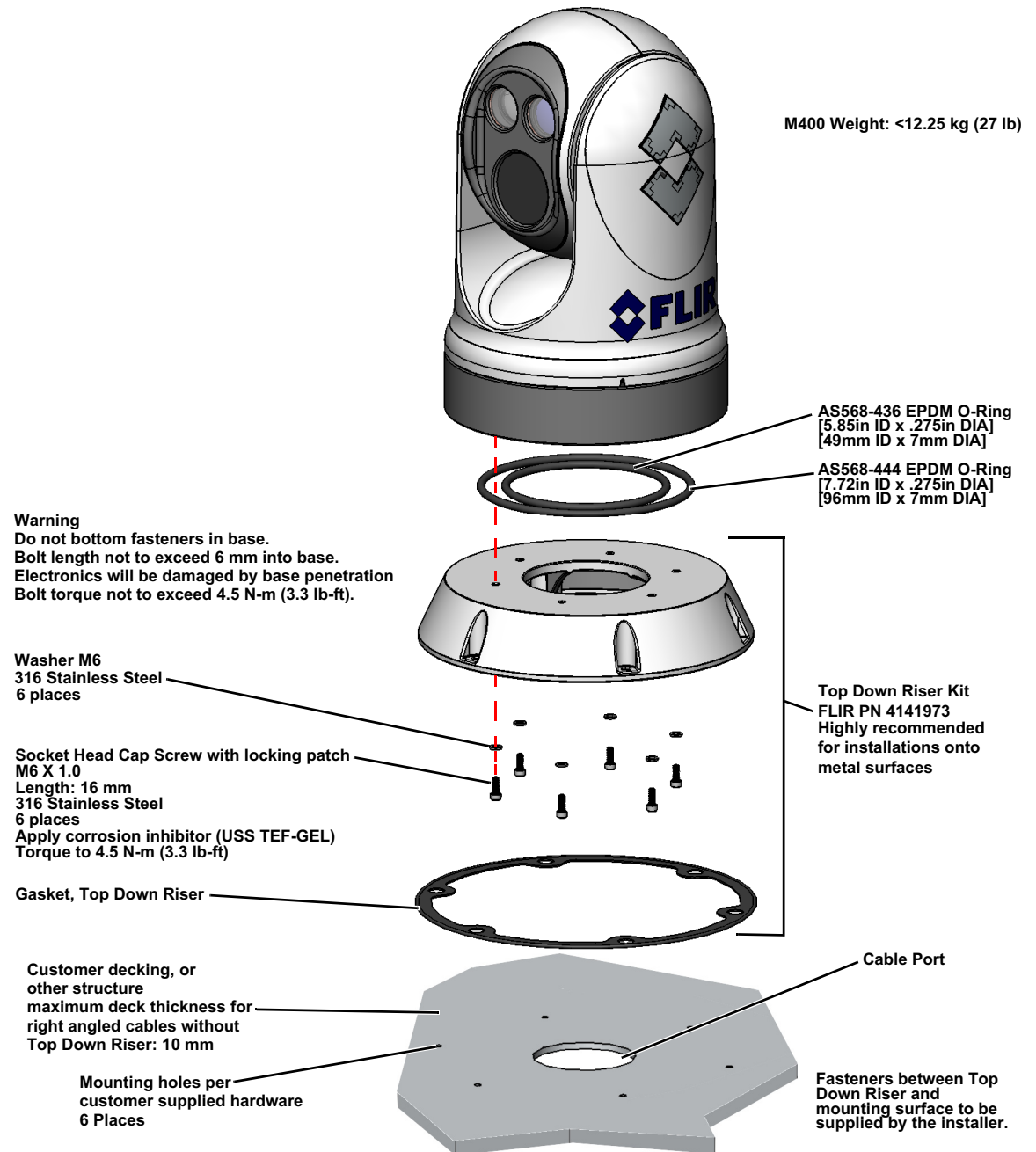

Figure A-1: M400 Top Down Riser Installation—Ball up

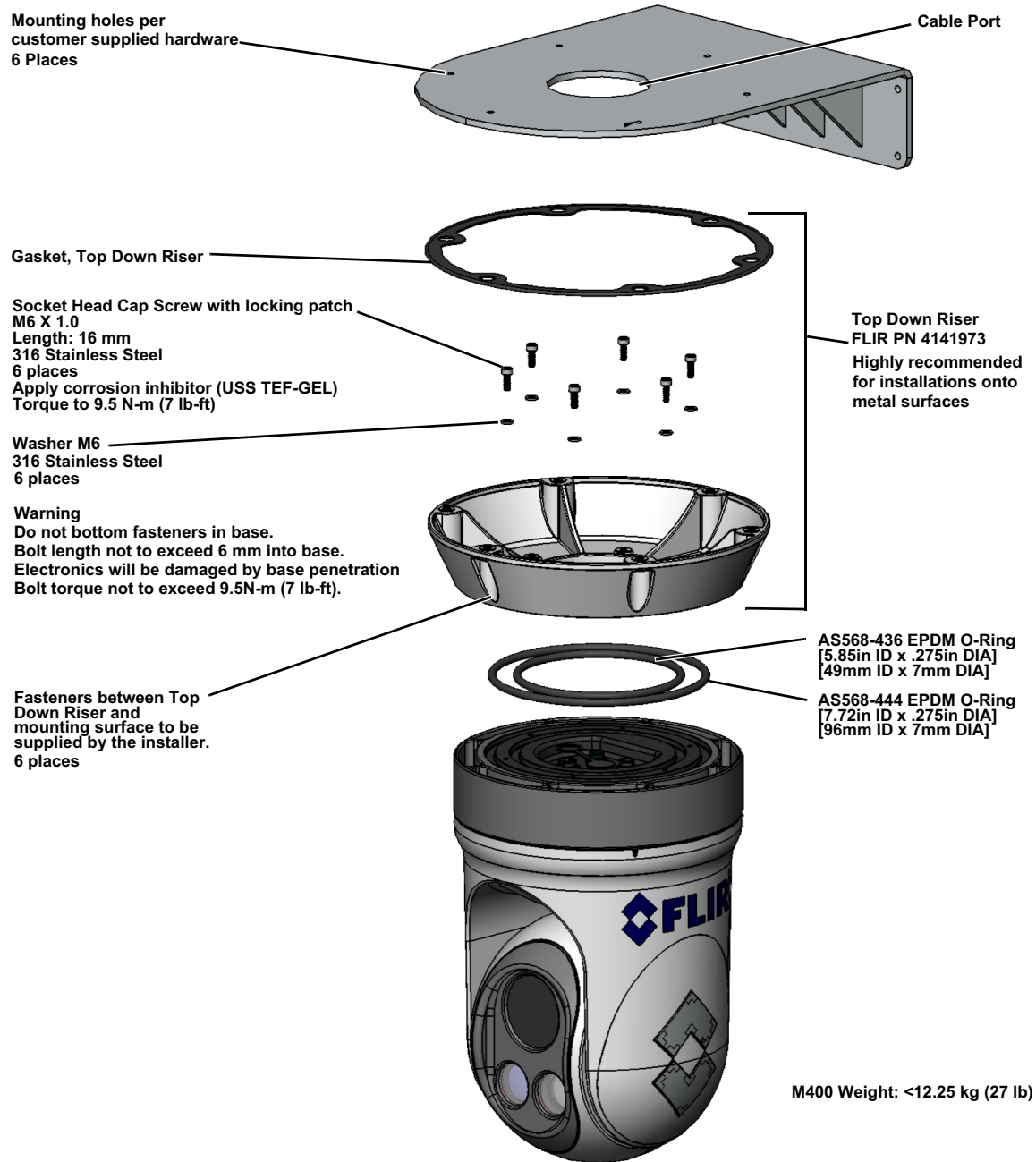

Figure A-2: M400 Top Down Riser Installation—Ball down

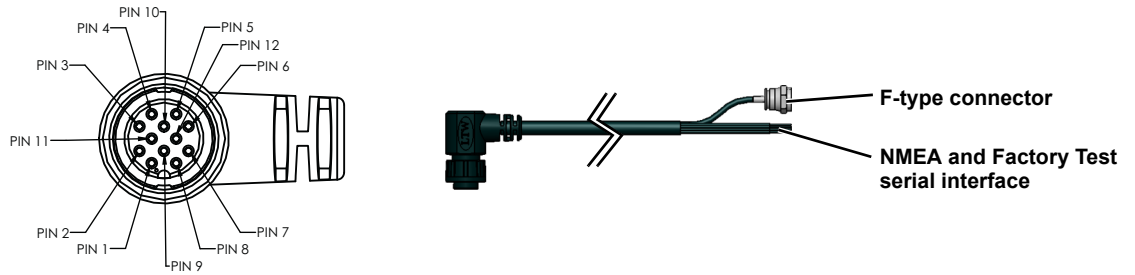

Figure A-3: Analog Video and Serial Cable

TABLE A.1 Analog Video and Serial Cable Pinout

Pin #	Signal Name	Wire Color
1	Factory TX-P	GREEN
2	Factory TX-N	GREEN/WHITE
3	ANALOG VIDEO OUT	RG179
4	ANALOG VIDEO RETURN	NATURAL
5	NMEA RX-N	BROWN/WHITE
6	NMEA RX-P	BROWN
7	NMEA TX-P	BLUE
8	Factory RX-N	ORANGE/WHITE
9	Factory RX-P	ORANGE
10	NMEA SHIELD	DRAIN
11	Factory SHIELD	DRAIN
12	NMEA TX-N	BLUE/WHITE

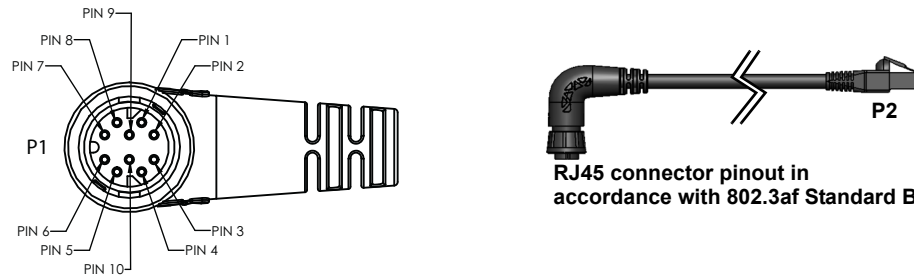

Figure A-4: Ethernet Cable

TABLE A.2 Ethernet Cable Pinout

P1 Pin #	Signal Name	Wire Color	P2 Pin #
1	TXRX A+	ORANGE/WHITE	1
2	TXRX A-	ORANGE	2
3	TXRX C+ DC+	BLUE	4
4	TXRX C- DC+	BLUE/WHITE	5
5	TXRX B+	GREEN/WHITE	3
6	TXRX B-	GREEN	6
7	TXRX D+ DC-	BROWN/WHITE	7
8	TXRX D- DC-	BROWN	8
9		NA	NA
10	DRAIN	DRAIN	SHELL

TABLE A.3 Power Cable Pinout

Signal Name	Wire Color
BATT +	RED
BATT -	BLACK
CHASSIS GROUND	DRAIN

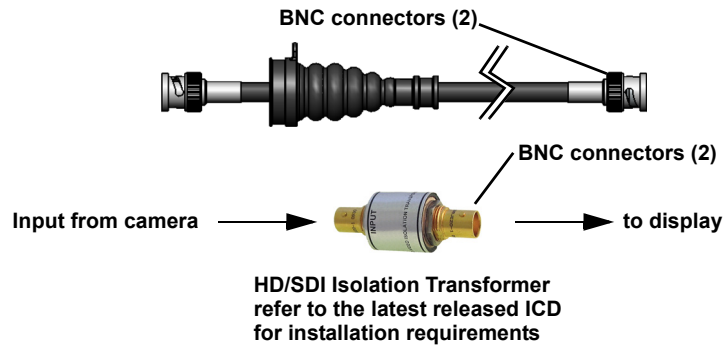
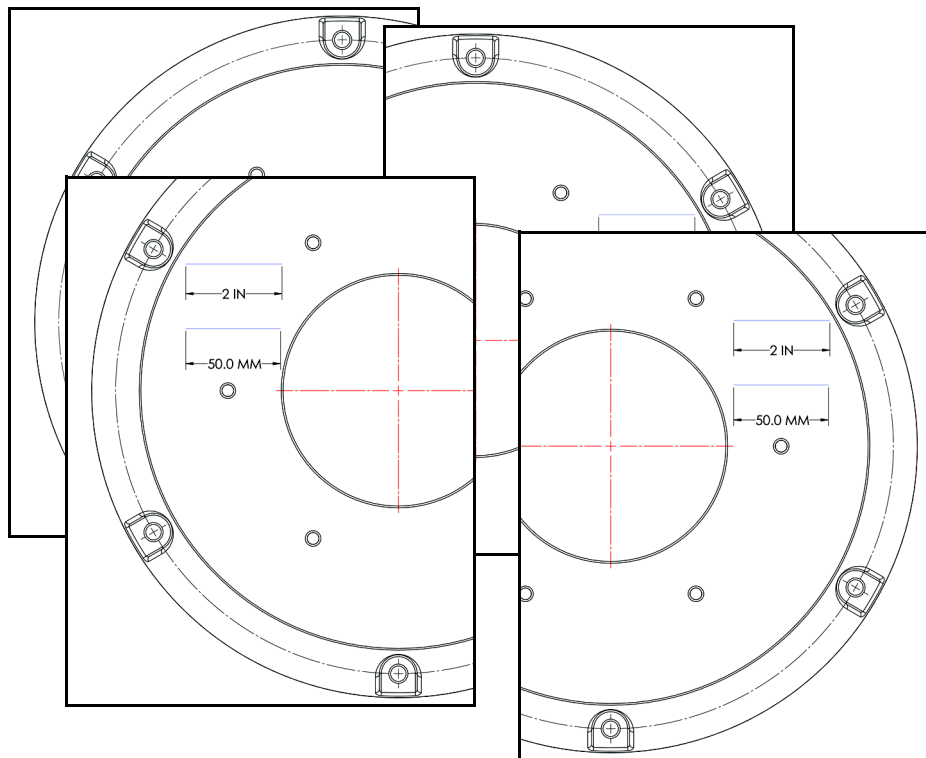

Figure A-5: HD-SDI Cable

M400 Top Down Riser Installation Template

The following four pages provide a mounting template for the M400 camera using the top down riser which can be printed on a standard printer using either 8.5x11 or A4 paper. See “M400 Riser Installation Document” on page 36. for dimensions.

1. Ensure printer margins are set to zero and scale is 100%.
2. After printing verify the scale dimensions of the key on each page.
3. Align the center cross on the sheets to get a full 13 in. by 13 in. template.



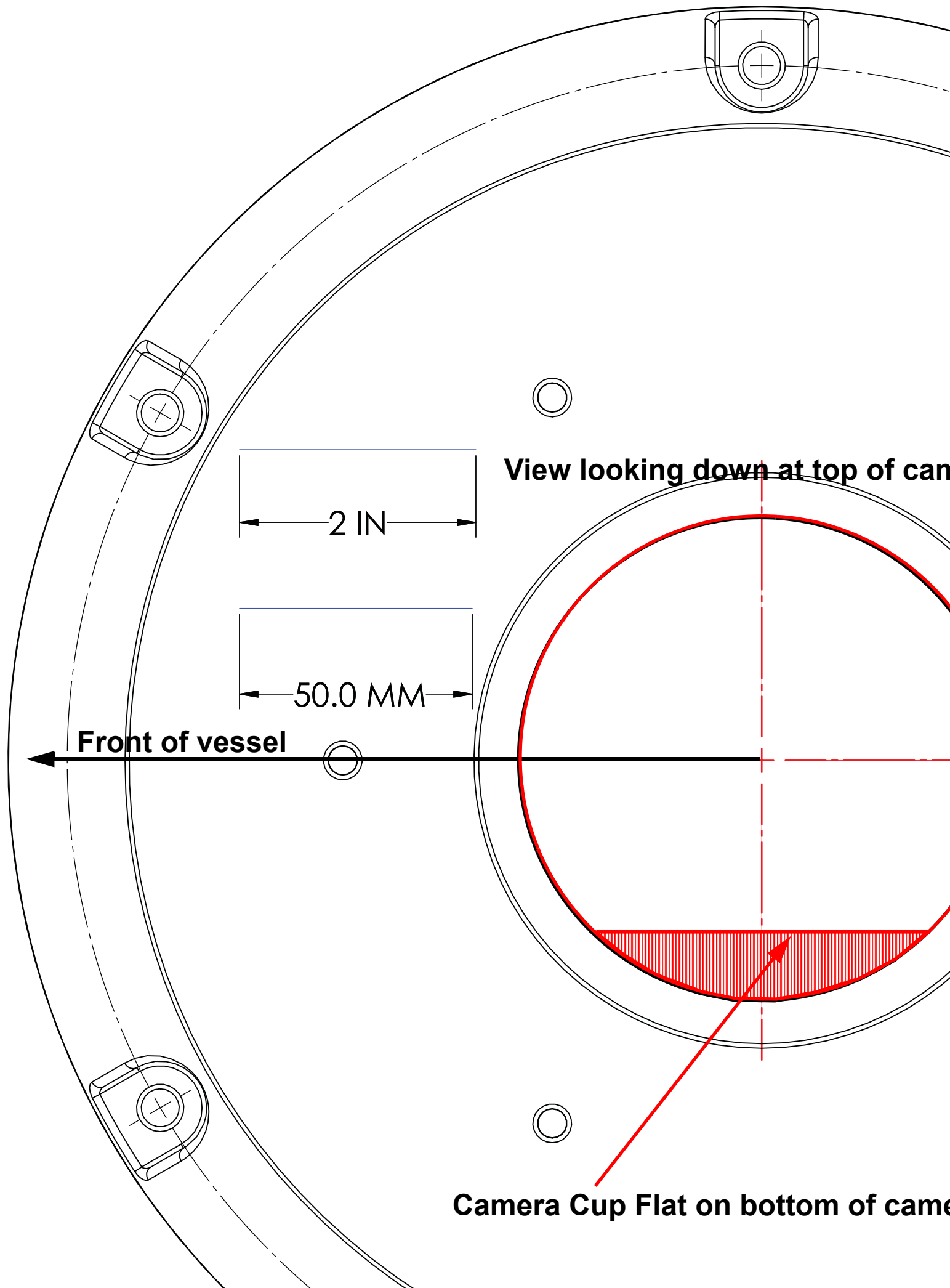

Front of vessel

2 IN

50.0 MM

View looking down at top of camera

Camera Cup Flat on bottom of camera

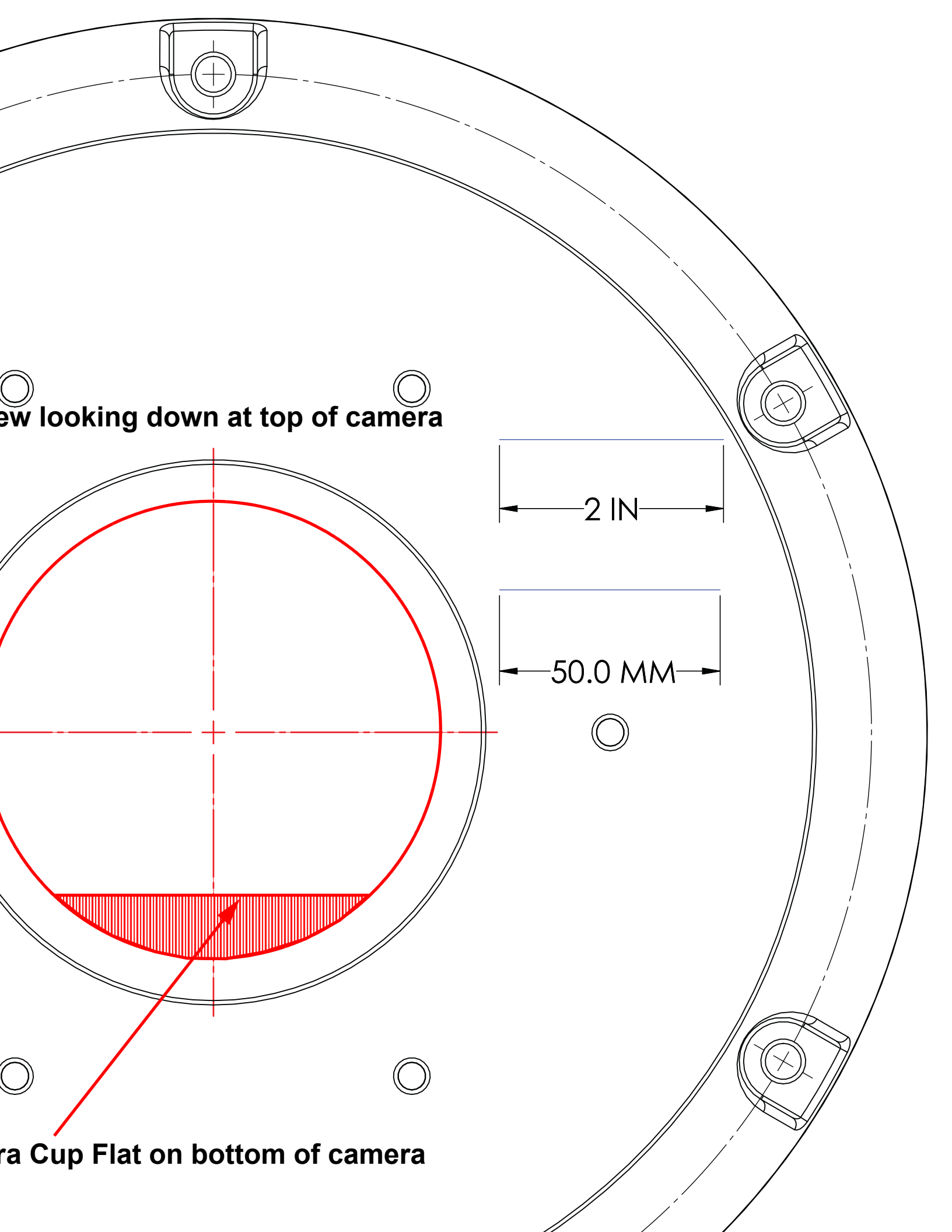

View looking down at top of camera

2 IN

50.0 MM

Camera Cup Flat on bottom of camera

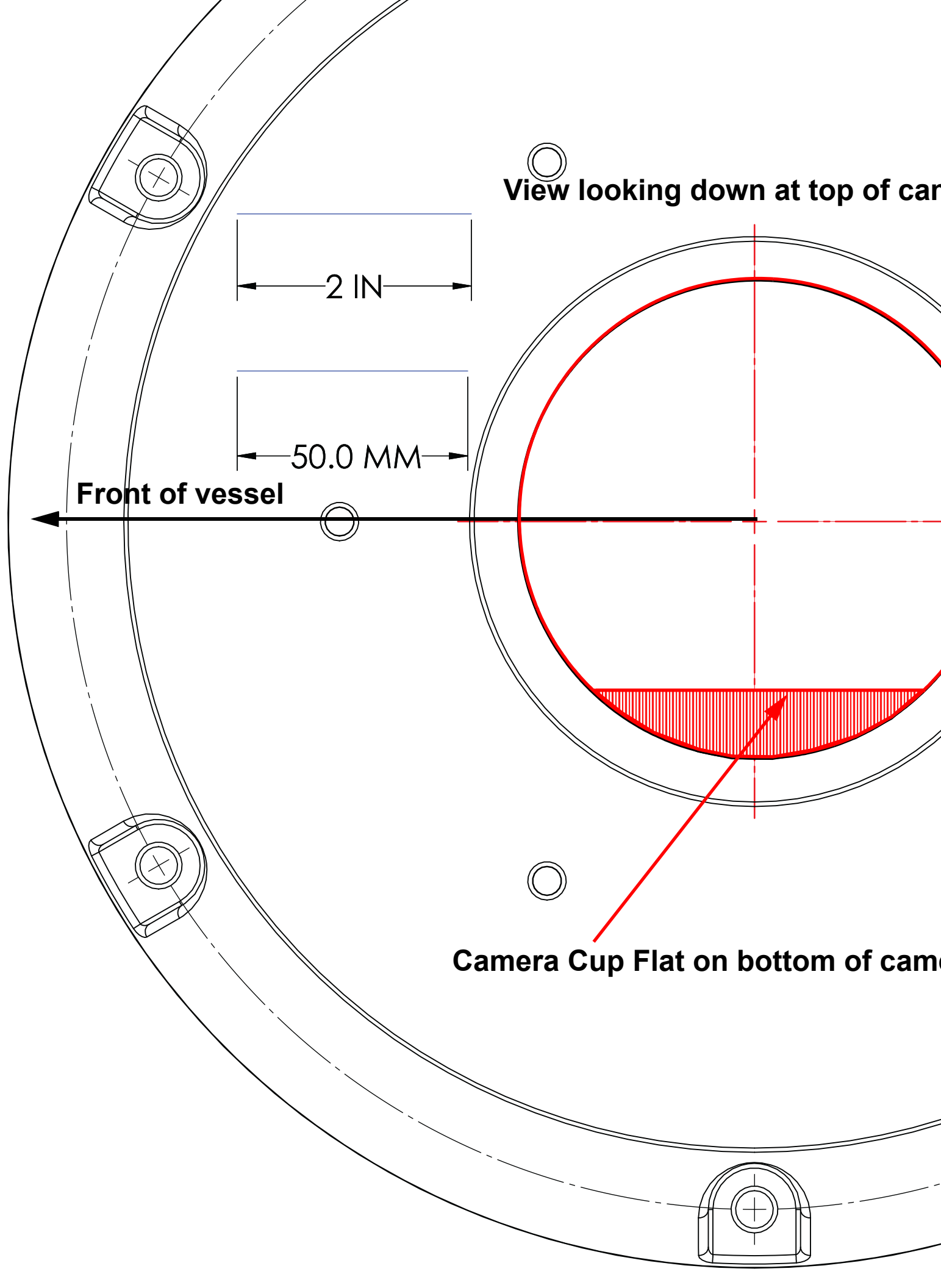

View looking down at top of camera

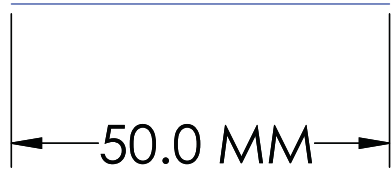
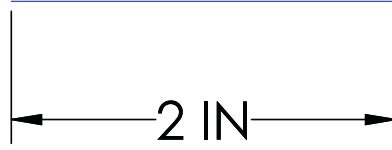
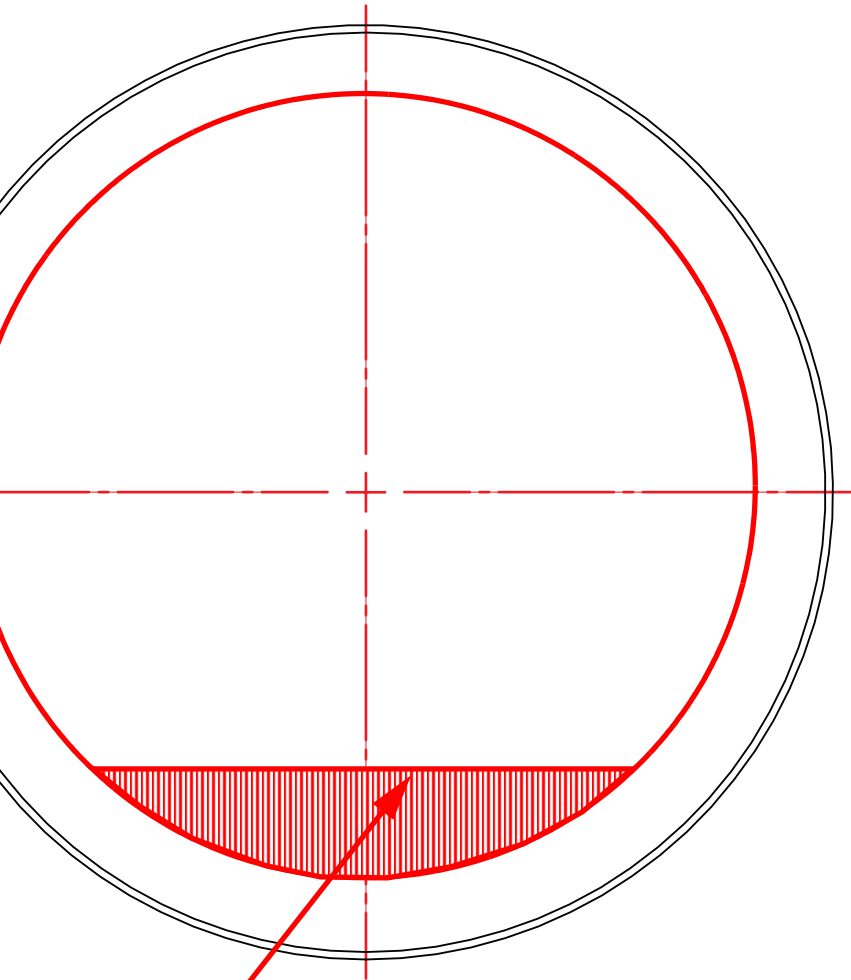

Camera Cup Flat on bottom of camera

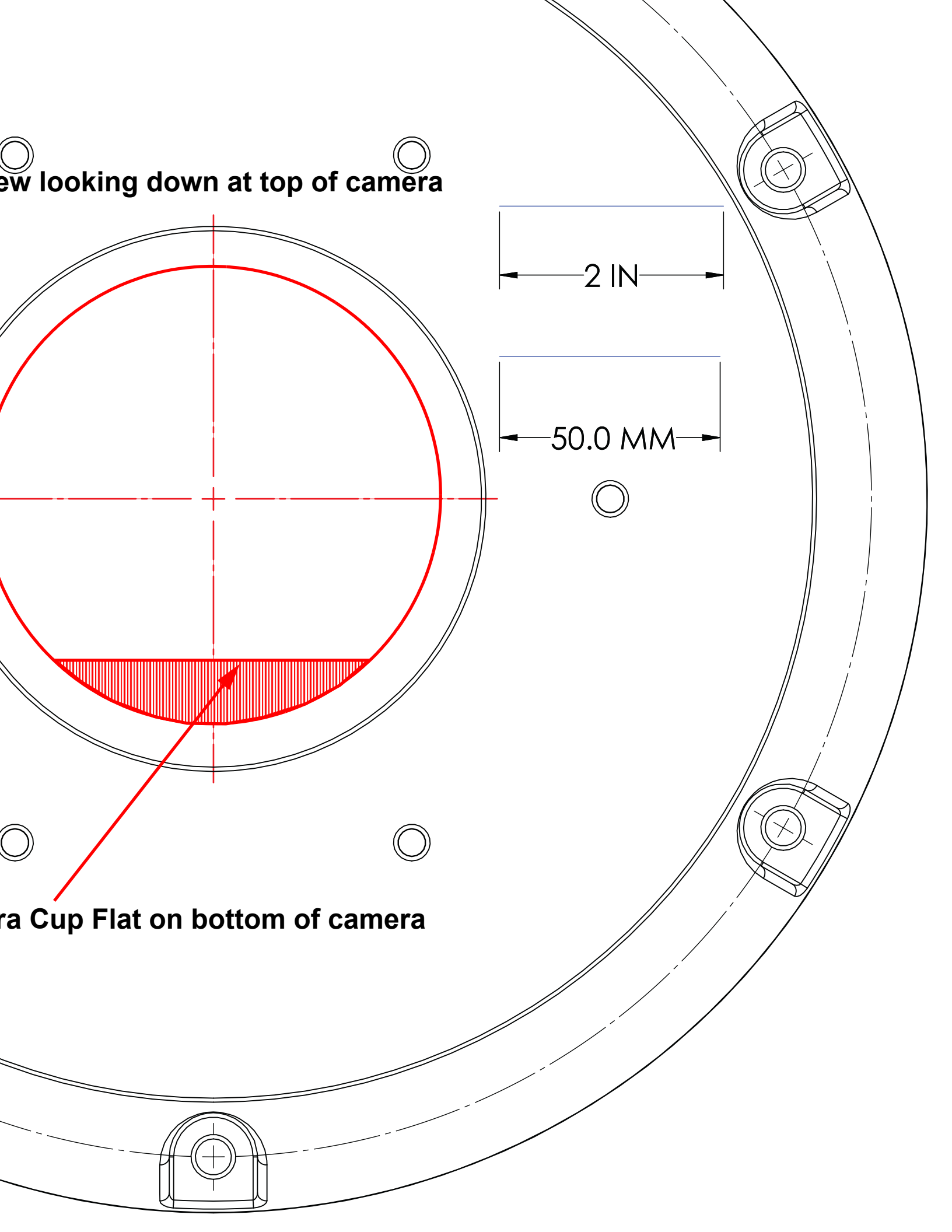

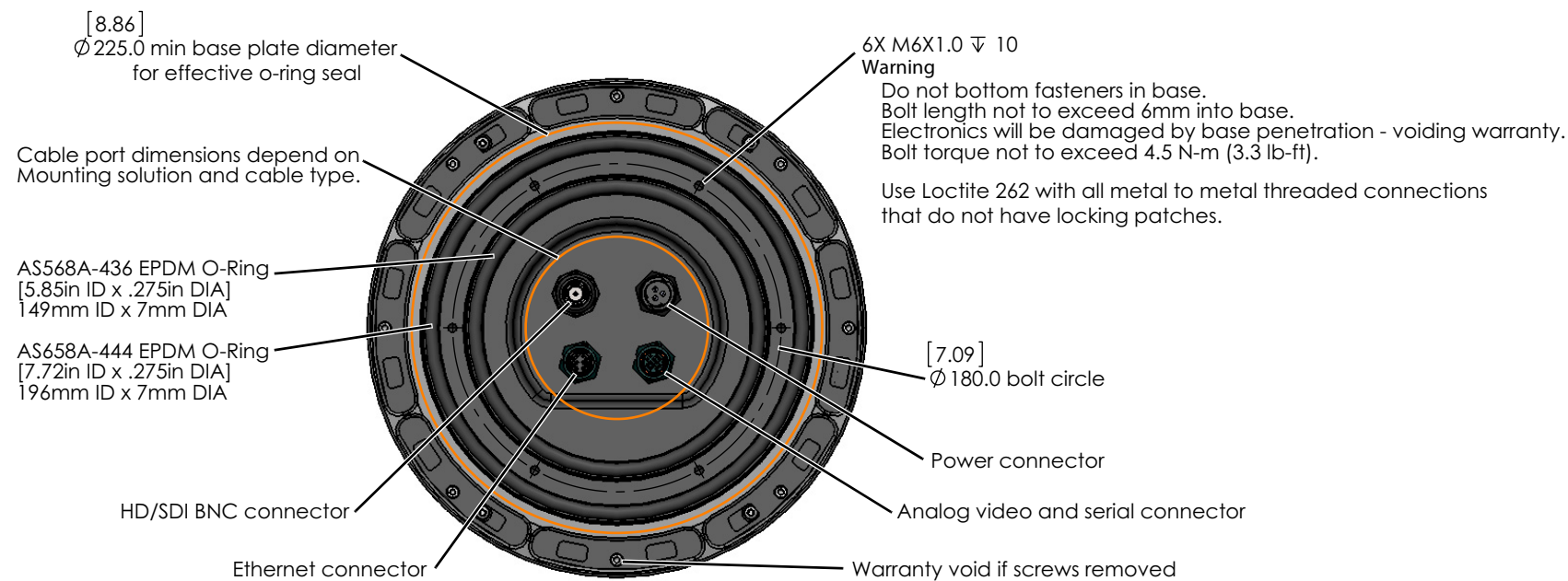
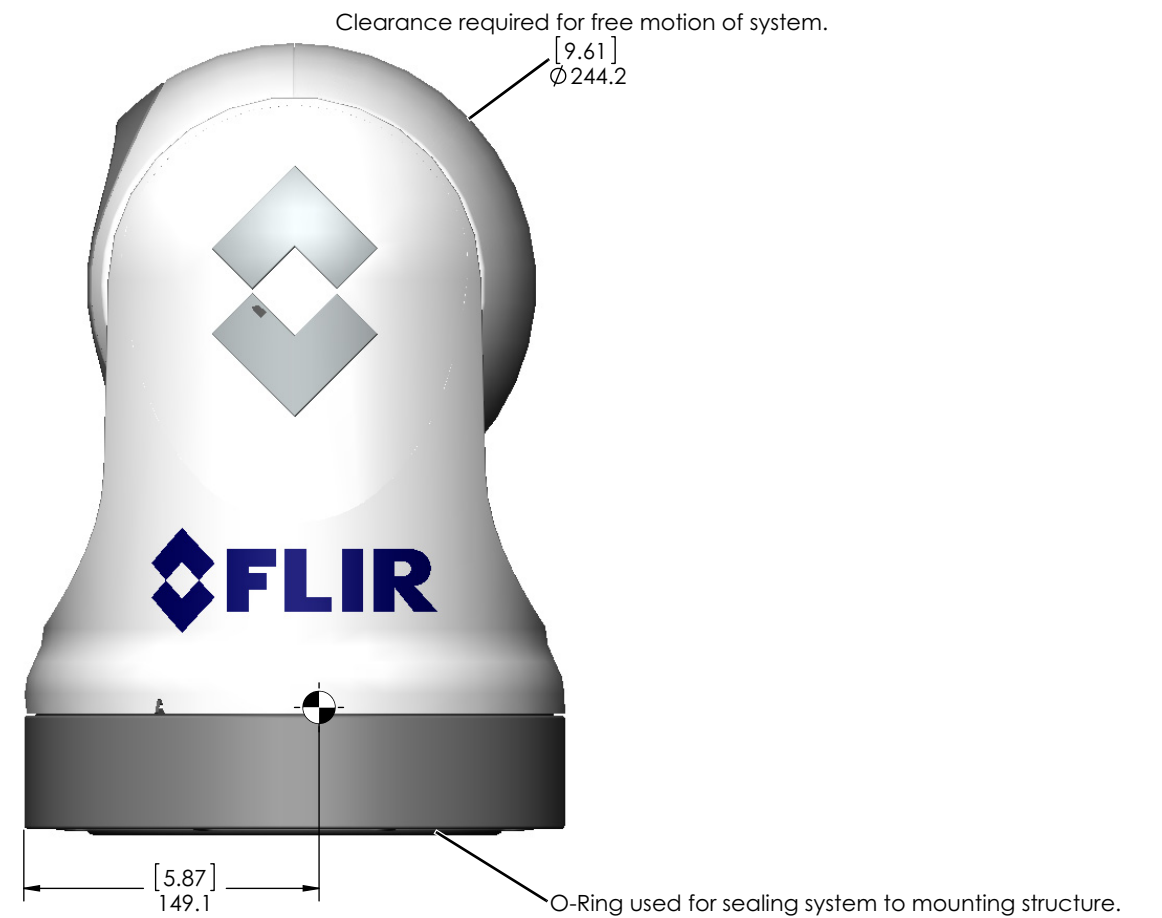
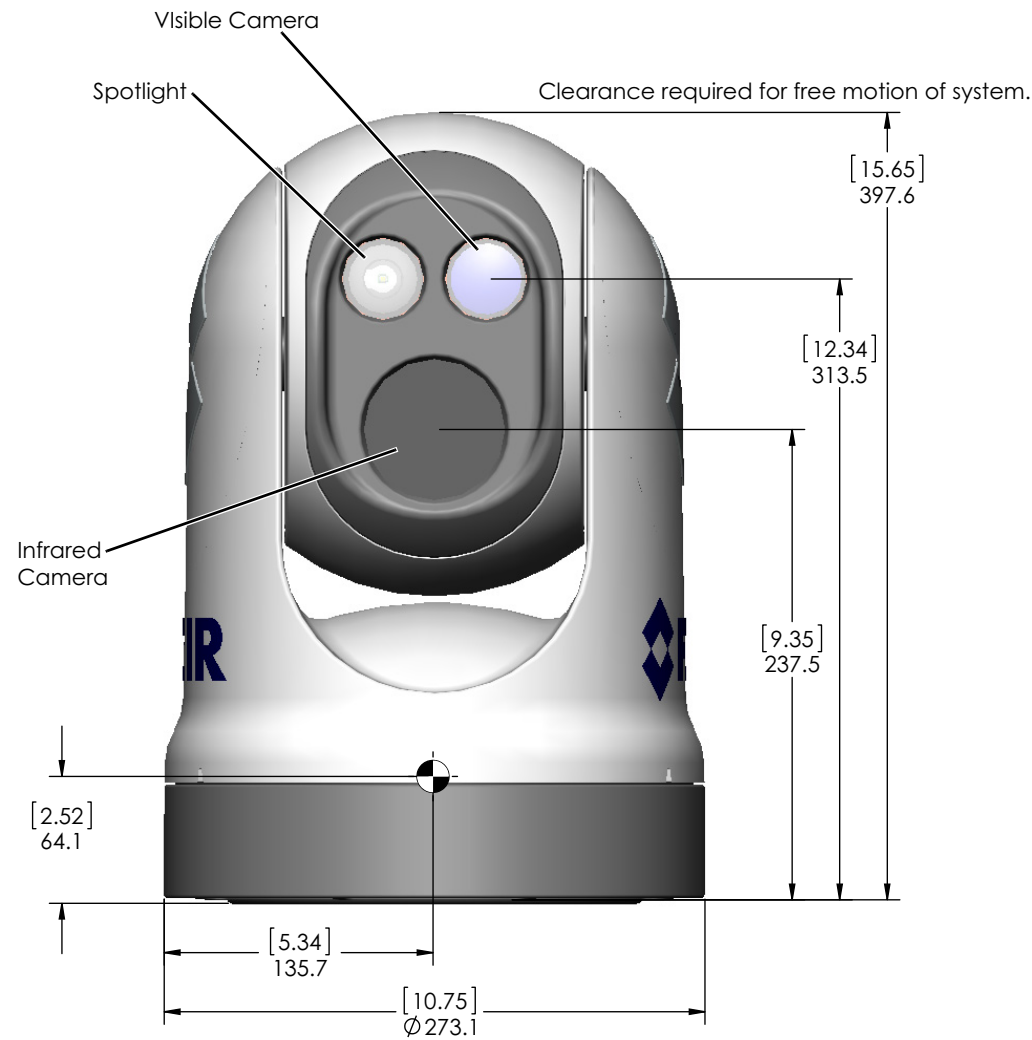

All dimensions are in mm and (inches)

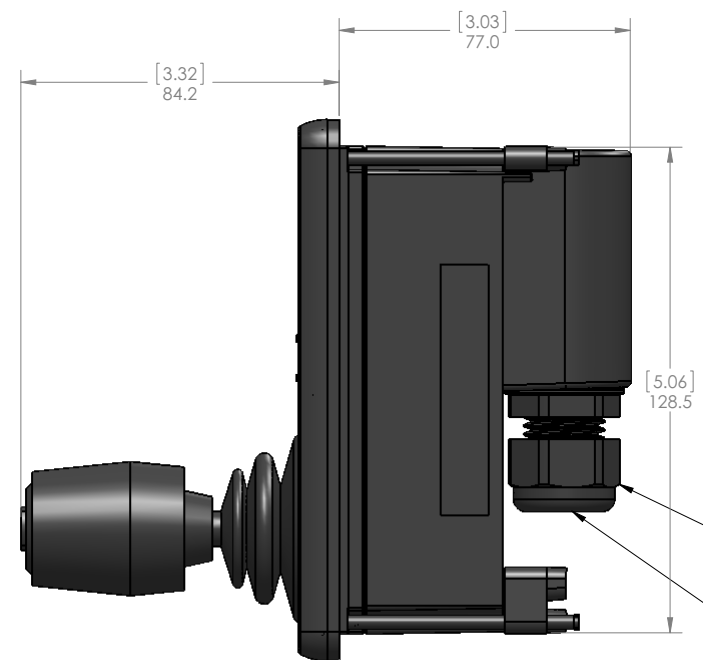
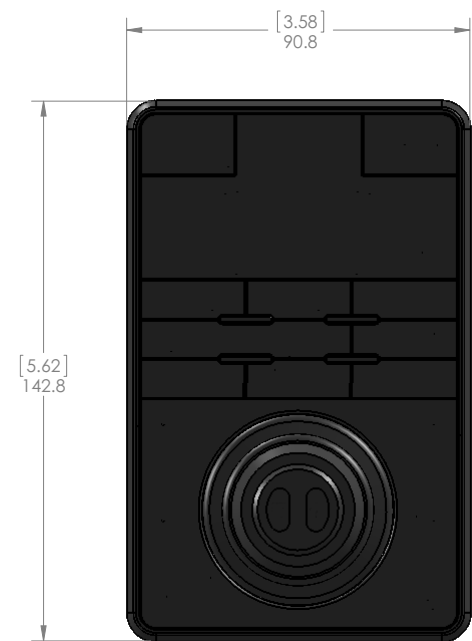

WITH CABLE INSTALLED, TURN NUT 1/4 TURN BEYOND HAND TIGHT.

GLAND SEAL DESIGNED FOR USE WITH DOUBLE SHIELDED CAT 5 ETHERNET CABLE. USE OF SINGL SHIELDED CABLE MAY REQUITE THE USE OF ADDITIONAL SEALENT SUCH AS SILICON OR RTV TO ENSURE SEALING OF ENCLOSURE

INSERT NETWORK CABLE RJ45 THROUGH GLAND NUT AND SEAL BEFORE INSTALLING

IP66 RATED ABOVE GASKET.

IP64 RATED BEHIND GASKET.

APPLY ADHESIVE SIDE OF GASKET TO JCU BODY.

MOUNTING PANEL THICKNESS RANGE 1.6-45 [0.036-1.750]. WHEN MOUNTING TO PANEL LESS THAN 6.3 [0.25] REVERSE PADDLES.

DURING INITIAL TIGHTENING, ENSURE MOUNTING TABS ON SCREWS SWING FREE OF REAR HOUSING. WITH TABS RUN UP AGAINST REAR OF INSTRUMENT PANEL, TIGHTNE 1/4 - 1/2 TURN BEYOND HAND TIGHT.

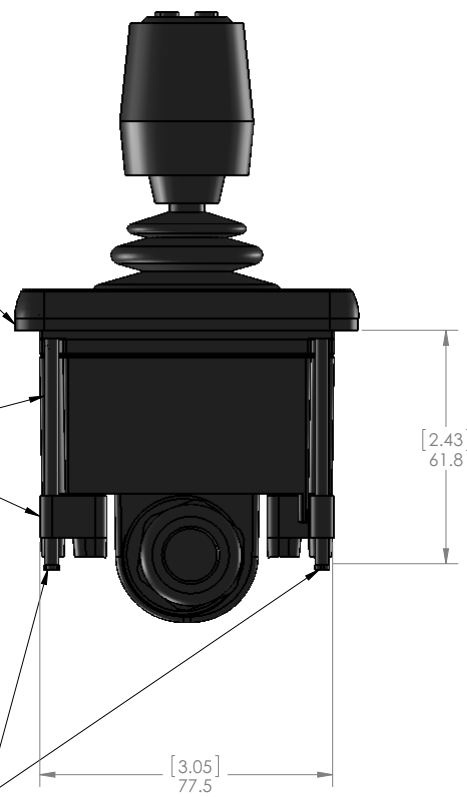

All dimensions are in mm and (inches)

CORNERS SHALL BE SHARP.

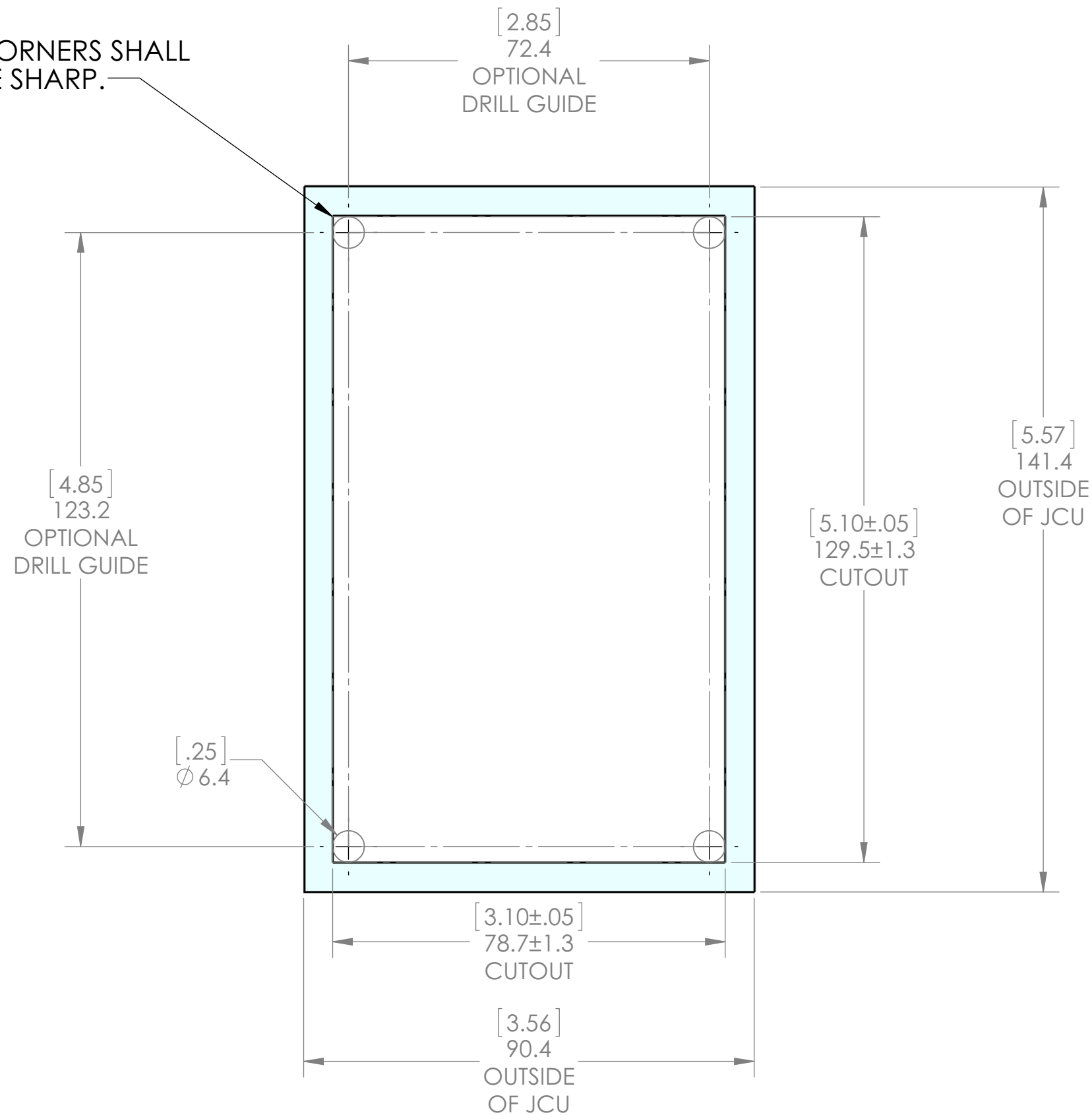

IMPORTANT NOTE:

PAPER SIZE: 11x17in
TEMPLATE SHOULD PRINT 1:1

DUE TO VARIATION IN SOFTWARE AND
PRINTER, PLEASE VERIFY SCALE BELOW
BEFORE MODIFYING MOUNTING SURFACE.

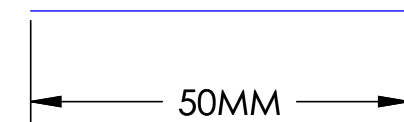
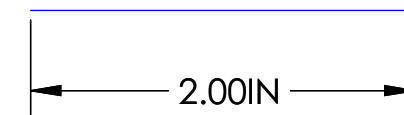

All dimensions are in mm and (inches)

[11.75]
Ø 298.5
Top down riser bolt circle

[.32]
6X Ø 8.2 Riser Clearance Holes
Recommend:
M8 socket head cap screws, or
5/16" - 18 socket head cap screws, or
5/16" - 18 hex head sheet metal screws
Type and length dependant on mounting surface
316 stainless steel
Apply thread locker (Loctite 262 or equivalent)

[7.09]
Ø 180.0
Base cup hole circle

[12.75]
Ø 323.9
Top Down Riser OD

[4.79]
Ø 121.6 Riser cable clearance hole
Recommended deck port:
Ø 30.0 [1.18] min
Ø 130.0 [5.12] max

NOT TO SCALE

